

TR10A073-B RE / 02.2012

DE

Anleitung für Montage, Betrieb und Wartung

Steuerung Garagen-Rolltorantrieb

EN

Instructions for Fitting, Operating and Maintenance

Control for Roller Garage Door Operator

FR

Instructions de montage, d'utilisation et d'entretien

Motorisation de rideau à lames de garage

NL

Handleiding voor montage, bediening en onderhoud

Besturing voor de aandrijving van de garageroldeur

IT

Instrucciones de montaje, funcionamiento y mantenimiento

Cuadro de maniobra del automatismo para puerta de garaje enrollable

ES

Istruzioni per il montaggio, l'uso e la manutenzione

Centralina di comando per motorizzazione per serrande avvolgibili da garage

PT

Instruções de montagem, funcionamento e manutenção

Comando de automatismo para porta de enrolar de garagem

A

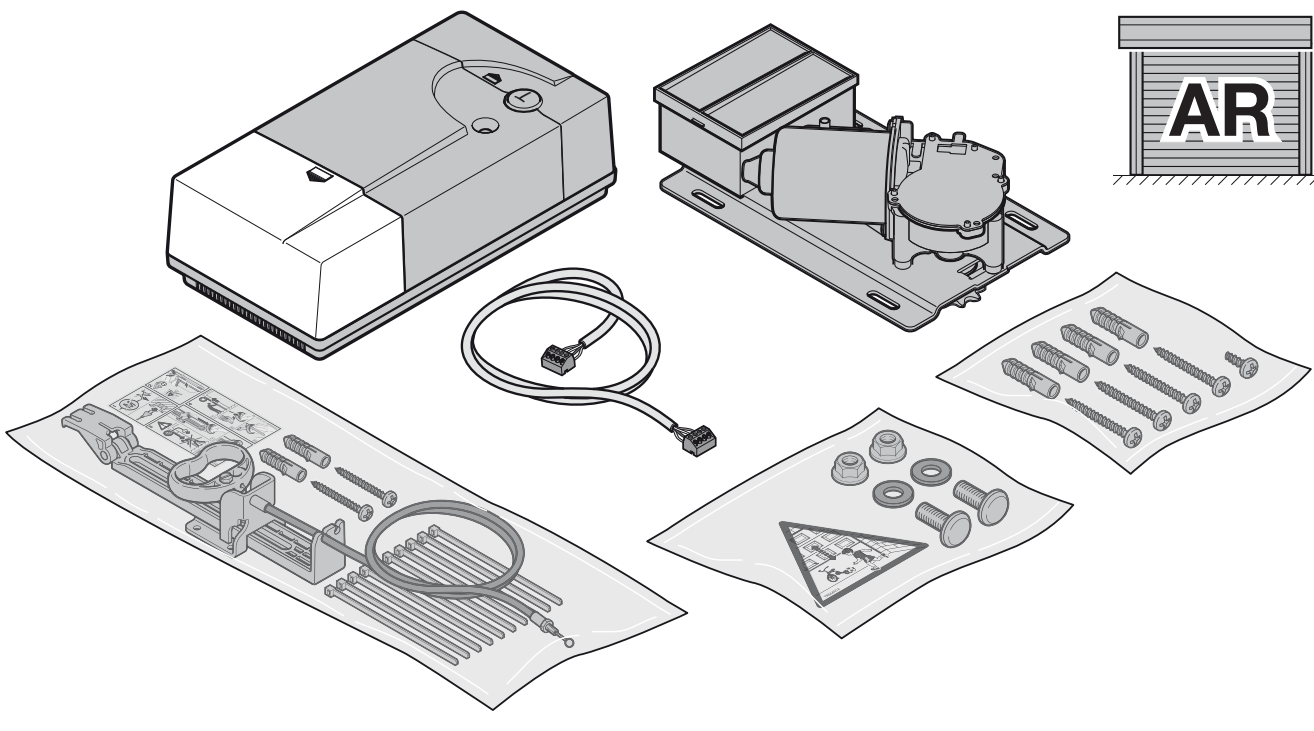
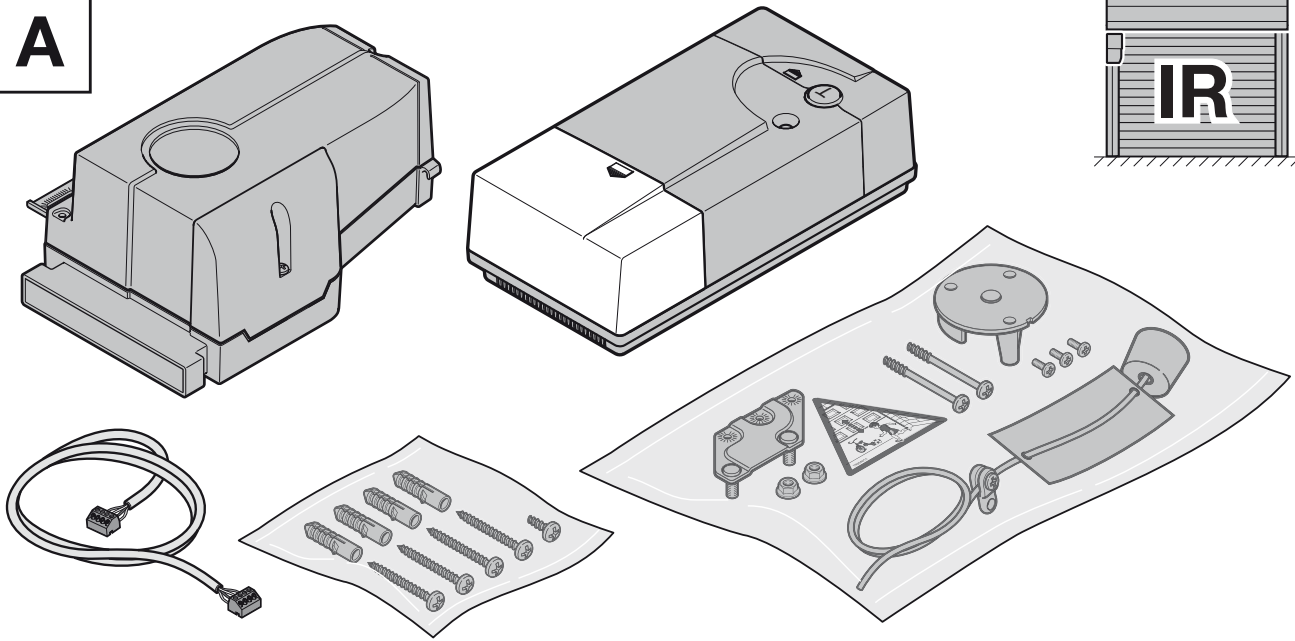

B

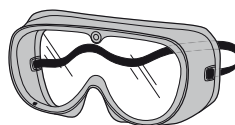
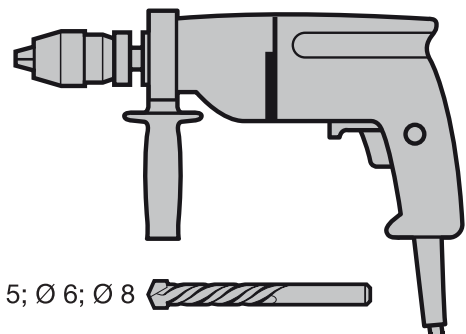

Ø 5; Ø 6; Ø 8



Ø 3.7



Contents

A	Articles supplied	2		
B	Tools needed for fitting	2		
1	About These Instructions	21		
1.1	Further applicable documents	21		
1.2	Warnings used	21		
1.3	Definitions used	21		
1.4	Symbols used	21		
1.5	Abbreviations used	22		
2	⚠ Safety Instructions	22		
2.1	Intended use	22		
2.2	Non-intended use	22		
2.3	Fitter qualification	22		
2.4	Safety instructions for fitting, maintenance, repairs and disassembly of the door system	22		
2.5	Safety instructions for fitting	22		
2.6	Safety instructions for initial start-up and for operation	23		
2.7	Safety instructions for using the hand transmitter	23		
2.8	Approved safety equipment	23		
2.9	Safety instructions for inspection and maintenance	23		
3	Fitting	23		
3.1	Preparation for Installation	23		
3.2	Electrical connection	24		
3.3	Connecting additional components to the circuit board	24		
3.4	Connecting additional components to the motor connection circuit board	25		
4	Putting the Control Into Service	25		
4.1	Preparations	25		
4.2	Factory reset	26		
4.3	Setting additional functions via the DIL switches ...	26		
5	Radio	27		
5.1	Hand transmitter HSM 4	27		
5.2	Extending the remote control with additional hand transmitters HS 1, HS 4, HSM 4 or HSE 2	28		
5.3	Integrated radio receiver	28		
5.4	Programming the hand transmitter buttons on an integrated radio receiver	29		
5.5	Deleting all data in an integrated radio receiver	29		
5.6	Excerpt from the declaration of conformity for the receiver	29		
6	Operation	29		
6.1	Instructing users	29		
6.2	Function check	29		
6.3	Normal operation	30		
6.4	Partial opening	30		
6.5	Operator light	30		
6.6	Mains failure bridging using an emergency battery HNA 18	30		
6.7	Operation after the decoupling mechanism (mechanical release) has been actuated	30		
7	Operator light	30		
7.1	Operator light	30		
7.2	Messages when mains voltage is on	31		
7.3	Maintenance display	31		
8	Operation, error and warning messages	31		
9	Inspection and Maintenance	32		
9.1	Replacement bulb	32		
10	Optional accessories	32		
11	Dismantling and Disposal	32		
12	Warranty Conditions	32		
12.1	Performance	33		
13	Excerpt from the Declaration of Incorporation	33		
14	Technical data	33		
15	Overview of DIL switch functions	34		
16	Overview of errors and troubleshooting	35		
	Illustrated section	123		

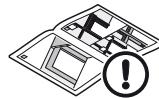

Dissemination as well as duplication of this document and the use and communication of its content are prohibited unless explicitly permitted. Non-compliance will result in damage compensation obligations. All rights reserved in the event of patent, utility model or design model registration. Subject to changes.

Dear customer,
We are delighted that you have chosen a high-quality product from our company.

1 About These Instructions

These instructions are **original operating instructions** as outlined in the EC Directive 2006/42/EC. Read through all of the instructions carefully, as they contain important information about the product. Pay attention to and follow the instructions provided, particularly the safety instructions and warnings.





Please keep these instructions in a safe place and make sure that they are available to all users at all times.

1.1 Further applicable documents

The following documents for safe handling and maintenance of the door system must be placed at the disposal of the end user:

- These instructions
- Fitting instructions for roller garage door
- The enclosed test manual

1.2 Warnings used

	The general warning symbol indicates a danger that can lead to injury or death . In the text, the general warning symbol will be used in connection with the caution levels described below. In the illustrated section, an additional instruction refers back to the explanation in the text section.
 DANGER	Indicates a danger that can immediately lead to death or serious injuries.
 WARNING	Indicates a danger that can lead to death or serious injuries.
 CAUTION	Indicates a danger that can lead to minor or moderate injuries.
ATTENTION	Indicates a danger that can lead to damage or destruction of the product .

1.3 Definitions used

Hold-open phase

Waiting phase at the *Open* end-of-travel position before the door closes with an automatic timer

Automatic timer

Automatic closing of the door after a set time has elapsed and after reaching the *Open* end-of-travel position.

DIL switches

Switches on the control circuit board for setting the control.

Impulse control

With each push of the button, the door is started against the previous direction of travel or the motion of the door is stopped.

Force learning run

The forces necessary for door travel are taught in during this learning run.

Photocell

The photocell acts as a safety device in the *Close* direction. If the photocell is activated while the door is moving towards the *Close* end-of-travel position, the door will stop and move towards the *Open* end-of-travel position. If the "automatic timer" function is activated, the remaining hold-open phase is stopped and set to a preset value (30 seconds) when the door (*Open* end-of-travel position) and the photocell are passed through.

Reference run

Door cycle with reduced speed towards the *OPEN* end-of-travel position in order to set the home position.

Reverse cycle / safety reversal

Door travels in the opposite direction on activation of the safety devices (via force limit for approx. 60 cm, via photocell to the *OPEN* end-of-travel position).

Partial opening

The door only moves to a programmed height. This is only possible via the remote control.









Pre-warning time

The time between the travel command (impulse) and the start of travel.

Factory reset

Reset the taught-in values back to the factory setting.

1.4 Symbols used

	See text section
	In the example, 2.2 means: See text section, section 2.2
	See illustrated section
	Internal roller garage door Fitting in or behind the opening
	External roller garage door Fitting in front of the opening
	Operator unlocked
	Operator locked
	Audible engagement



DIL switch factory setting

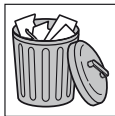

Remove and dispose of component or packaging

NOTE:

All specified dimensions in the illustrated section are in [mm].

1.5 Abbreviations used

Colour code for cables, single conductors and components			
The abbreviations of the colours for identifying the cables, conductors and components comply with the international colour code according to IEC 757:			
BK	Black	RD	Red
BN	Brown	WH	White
GN	Green	YE	Yellow
Article designations			
HE 1	1-channel receiver		
HE 2	2-channel receiver		
HE 3	3-channel receiver		
IT 1	Internal push button with impulse button		
IT 1b	Internal push button with illuminated impulse button		
EL 101	One-way photocell		
EL 301	One-way photocell		
HOR 1	Option relay		
HSM 4	4-button mini hand transmitter		
HNA 18	Emergency battery		

2 Safety Instructions

ATTENTION:

IMPORTANT SAFETY INSTRUCTIONS.
FOR THE SAFETY OF PERSONS, IT IS IMPORTANT TO COMPLY WITH THE FOLLOWING INSTRUCTIONS. THESE INSTRUCTIONS MUST BE KEPT.

2.1 Intended use

The roller garage door operator is designed and intended exclusively for the operation of smooth-running, spring-compensated roller garage doors in the domestic, non-commercial sector. The maximum permissible door size and maximum weight must not be exceeded.

Note the manufacturer's specifications regarding the door and operator combination. Potential hazards as outlined in DIN EN 13241-1 are avoided by construction and fitting according to our guidelines. Door systems that are located in a public area and which only have one protective device, such as a power limit, may only be operated under supervision.

The roller garage door operator is designed for operation in dry areas.

2.2 Non-intended use

Use in the commercial sector is prohibited.

2.3 Fitter qualification

Only correct fitting and maintenance in compliance with the instructions by a competent / specialist company or a competent / qualified person ensures safe and flawless operation of the system. According to EN 12635, a specialist is a person with suitable training, specialist knowledge and practical experience sufficient to correctly and safely fit, test and maintain a door system.

2.4 Safety instructions for fitting, maintenance, repairs and disassembly of the door system

DANGER
Compensating springs are under high tension
▶ See warning in section 3.1

Fitting, maintenance, repairs and disassembly of the door system and roller garage door must be performed by a specialist.

- ▶ In the event of a failure of the roller garage door operator, a specialist must be commissioned immediately to perform an inspection or carry out repairs.

2.5 Safety instructions for fitting

The specialist carrying out the work must ensure that installation is conducted in compliance with the prevailing occupational safety rules and regulations and those governing the operation of electrical equipment. The relevant national guidelines must be observed. Potential hazards as outlined in DIN EN 13241-1 are avoided by construction and fitting according to our guidelines.

The roller garage door operator is designed for operation in dry areas.

	DANGER
Mains voltage	
▶ See the warning in section 3.2 and section 9.1	

WARNING
Danger of injury due to damaged components
▶ See warning in section 3.1
Danger of injury due to unexpected door travel
▶ See warning in Section 3.3.5

CAUTION
Danger of crushing in the side guides
▶ See warning in section 3.1

2.6 Safety instructions for initial start-up and for operation

WARNING

Danger of injury during door travel

- ▶ See the warning in section 4.1, section 5 and section 6

CAUTION

Danger of door falling

- ▶ See warning in section 4.1

Danger of crushing in the side guide

- ▶ See warning in section 4.1 and section 6

Danger of injuries due to the hot lamp

- ▶ See warning in section 4.1 and section 9.1

2.7 Safety instructions for using the hand transmitter

WARNING

Danger of injury during door travel

- ▶ See warning in section 5.1

CAUTION

Danger of injuries due to unintended door travel

- ▶ See warning in section 5.1

2.8 Approved safety equipment

Safety relevant functions or components of the control, such as the force limit, external photocells, when installed, have been designed and approved in accordance with category 2, PL “c” of EN ISO 13849-1:2008.

WARNING

Danger of injuries due to faulty safety equipment

- ▶ See warning in section 4.2

2.9 Safety instructions for inspection and maintenance

WARNING

Danger of injury due to unexpected door travel

- ▶ See warning in section 9

3 Fitting

ATTENTION:

IMPORTANT INSTRUCTIONS FOR SAFE INSTALLATION. OBSERVE ALL INSTRUCTIONS, INCORRECT FITTING COULD RESULT IN SERIOUS INJURY.

3.1 Preparation for Installation

DANGER

Compensating springs are under high tension

Serious injuries may occur while adjusting or loosening the compensating springs!

- ▶ For your own safety, only have a specialist conduct work on the door compensating springs. The same applies to all maintenance and repair work!
- ▶ Never try to replace, adjust, repair or reposition the compensating springs for the counterbalance of the door or the spring mountings yourself.
- ▶ In addition, check the entire door system (joints, door bearings, cables, springs and fastenings) for wear and possible damage.
- ▶ Check for the presence of rust, corrosion and cracks.

A malfunction in the door system or an incorrectly aligned door can cause serious injuries!

- ▶ Do not use the door system if repair or adjustment work must be conducted!
- ▶ Only operate the roller garage door operator if you have full view of the door's area of travel during the entire time the door is in motion.
- ▶ Before driving in or out, always check that the roller garage door has fully opened. You may only drive or pass through the roller garage door when the door is at a standstill.

Before installing the operator and in the interests of personal safety, make sure that any necessary maintenance and repair work to the door system are carried out by a qualified specialist.

Only correct fitting and maintenance by a specialist company or a competent person in compliance with the instructions ensures safe and flawless operation of the system.

The specialist carrying out the work must ensure that installation is conducted in compliance with the prevailing occupational safety rules and regulations and those governing the operation of electrical equipment. The relevant national directives must be observed. Potential hazards are avoided by construction and fitting according to our guidelines.

- ▶ All safety and protective functions must be checked **monthly** to ensure that they are in working order. Any malfunctions and/or defects must be remedied immediately.

ATTENTION

Damage caused by dirt

When drilling, dust and chippings can lead to malfunctions.

- ▶ Cover the operator during drilling work.

Before fitting and operating the door system:

CAUTION

Danger of crushing in the side guides

Do not reach into the side guides with your fingers during door run, as this can cause crushing.

- ▶ Do not reach into the side guides during door travel

- ▶ All persons using the door system must be shown how to operate it properly and safely.
- ▶ Demonstrate and test the mechanical release as well as the safety reversal. To do this, stop the closing door by grasping it with both hands. The door system must initiate the safety reversal.
- ▶ In addition, check that the door is in a flawless mechanical condition, so that it can be easily operated by hand and opens and closes properly (EN 12604).

NOTE:

The fitter must check that the supplied fitting materials are suitable for the intended application and fitting location.

3.2 Electrical connection

	DANGER
Mains voltage	
<p>Contact with the mains voltage presents the danger of a deadly electric shock.</p> <p>For that reason, observe the following warnings under all circumstances:</p> <ul style="list-style-type: none"> ▶ Electrical connections may only be made by a qualified electrician. ▶ The on-site electrical installation must conform to the applicable protective regulations (230/240 V AC, 50/60 Hz)! ▶ Before performing any work on the operator, disconnect the mains plug or with direct wiring (see section 3.2.1) turn off the system power and prevent it from being switched on again in accordance with the safety regulations. 	

ATTENTION
<p>External voltage at the connecting terminals</p> <p>External voltage at the connecting terminals of the control will destroy the electronics.</p> <ul style="list-style-type: none"> ▶ Do not apply any mains voltage (230/240 V AC) to the connecting terminals of the control.

To prevent malfunctions:

- ▶ Duct the operator's connection cables (24 V DC) in an installation system that is separate from other supply lines (230 V AC).

3.2.1 Mains voltage

If needed, instead of the mains cable a fixed connection with 230/240 V AC, 50/60 Hz via an all-pole mains isolator switch with the appropriate pre-fuse can be used. Order from left to right = N, PE, L (see Figure 1.2).

3.3 Connecting additional components to the circuit board

To connect additional components, the flap of the control housing must be opened (see Figure 1.1). The terminals used to connect the radio receiver or additional components such as internal push buttons or safety equipment such as photocells, only have a safe low voltage of max. 30 V DC.

All connecting terminals can be given multiple assignments, but with a maximum of 1 x 2.5 mm² (see Figure 2). The mains plug must always be disconnected before connecting.

NOTE:

The voltage of approx + 24 V available at the connecting terminals cannot be used to power a light!

3.3.1 Connecting jack for extensions *

System jack for extensions, e.g. option relay for warning lamp *.

3.3.2 Connecting an additional external radio receiver *

In addition to, or instead of, an integrated radio module (see section 5.5.1), an external radio receiver can be connected:

- 1-channel radio receiver for the function impulse operation.
- 2-channel radio receiver for the functions impulse operation and operator light on / off
- 3-channel radio receiver for the functions impulse operation, operator light on / off, partial opening

Insert the plug of the receiver in the corresponding slot (see Figure 4).

3.3.3 Internal push button *

Internal push buttons are connected to the terminals on the left as shown in Figure 5-7.

- Type IT1 for the function impulse operation (see Figure 6)
- Type IT1b for the function impulse operation (see Figure 5)
- Type IT3b for the functions impulse operation (see Figure 7), operator light on / off (see Figure 7.1), radio operation is prevented (= holiday function, see Figure 7.2).

3.3.4 Connection for 2-wire photocell *

2-wire photocells (e.g. EL101, EL301) which are used as safety photocells and to monitor the automatic timer must be connected as shown in Figure 8 (observe **DIL switch 4** setting, section 4.3.3).

NOTE:

When fitting a photocell, make sure that the transmitter and receiver housings are fitted as close to the floor as possible – see the instructions for the photocell.

3.3.5 Emergency battery HNA 18 *

- ▶ Connect the emergency battery, as displayed in figure 9.1a.

To enable door movement in the event of a mains failure, an optional HNA 18 emergency battery can be connected. In the event of a mains failure, the system automatically switches to battery operation. During battery operation, the operator light remains switched off.

* Accessory, not included as standard equipment!

⚠ WARNING

Danger of injury due to unexpected door travel

Unexpected door travel can occur when the emergency battery HNA 18 is still connected despite the mains plug being pulled out.

- ▶ Disconnect
 - the emergency battery HNA 18 **and** mains plug, or with a fixed connection,
 - (see section 3.2.1) turn off the system power.
- ▶ Prevent the door system from being switched back on without authorisation in accordance with the safety regulations.

3.3.6 Signal transmitter for forced opening attempt *

A magnet switch fixed to the door can detect a forced opening attempt and activate a signal transmitter connected here (24 V max, 100 mA, Figure 9.1b) for max. 3 minutes (see section 3.4.4).

3.4 Connecting additional components to the motor connection circuit board

3.4.1 Terminal S1, static current circuit RSK 1

- ▶ See Figure 1.4

Connection of the switch to the decoupling mechanism (mechanical release, see section 6.7).

3.4.2 Terminal S2, static current circuit RSK 2

- ▶ See Figure 1.4

Connection of an optional safety switch.

3.4.3 Terminal S3, static current circuit RSK 3

- ▶ See Figure 1.4

Connection of an optional safety switch.

3.4.4 Terminal S4, magnet switch for forced opening attempt*

- ▶ See Figure 10

If the door is closed, a magnet switch fixed to the door can detect a forced opening attempt. Actuation of the switch connected here activates the signal transmitter (see section 3.3.6).

* Accessory, not included as standard equipment!

4 Putting the Control Into Service

4.1 Preparations

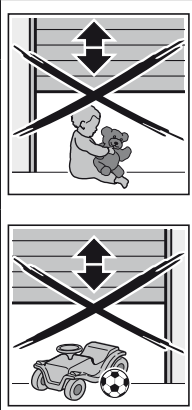
	<h2 style="text-align: center;">⚠ WARNING</h2>
	<p>Danger of injury during door travel</p> <p>If people or objects are near the door while the door is in motion, this can lead to injuries or damage.</p> <ul style="list-style-type: none"> ▶ Children are not allowed to play near the door system. ▶ Make sure that no persons or objects are in the door's area of travel. ▶ If the door has only one safety device, only operate the roller garage door operator if you are within sight of the door's area of travel. ▶ Monitor the door travel until the door has reached the end-of-travel position. ▶ Only drive or pass through remote control door systems if the door is in the Open end-of-travel position! ▶ Never stay standing under the open door.

⚠ CAUTION

Danger of door falling

Before the spring assembly is fitted, no persons may be located near the door, as it may fall. Do not come near the door until the spring assembly has been fitted.

Danger of crushing in the side guide

Do not reach into the side guide with your fingers during door travel, as this can cause crushing.

- ▶ Do not reach into the guide rail during door travel.

ATTENTION

Overloading the release knob

The release knob can be damaged by overloading.

- ▶ Do not hang on the release knob with your body weight.

⚠ CAUTION

Danger of injuries due to the hot lamp

Touching the lamp during or immediately following operation can lead to burns.

- ▶ Do not touch the lamp if it is switched on or was recently switched on.

During mechanical fitting of the roller garage door, the curtain can be rolled onto the shaft, by means of the operator. To do this, the operator and the control must be fitted and electrically connected to the 4-wire cable as specified in the "Instructions for Fitting, Operation and Maintenance of the Roller Garage Door".

The following steps must be completed:

4.1.1 Fitting

1. All DIL switches must be OFF.
2. Insert the control plug into the electric socket or activate the electrical fixed connection (see section 3.2.1). The rim of the large T button flashes quickly.
3. In press-and-hold operation (alternating Open - Close - Open - Close....as long as the button is held down), the curtain can now be rolled onto the shaft and, by moving up and down, fed into the side guide.
4. After fixing the curtain as specified in the "Instructions for Fitting, Operating and Maintenance, Roller Garage Door", check several times whether the door runs correctly.
5. Close the door halfway.

NOTE:

Check whether the grip handles (fixed) are fitted to the bottom weather seal.

4.1.2 Teaching in

▶ See Figure 11

1. DIL switch 1 to ON.

The rim of the large T button flashes 7x - pause - 7x - pause - etc. to show that the "operator has not been taught in yet".

2. Press the large T button 1x.

The Open reference run takes place automatically, followed by two Close / Open cycles to teach in the Close end-of-travel position and the forces. When the door stops in the Open end-of-travel position and the rim of the large T button flashes, the operator has been taught in.

3. Switch the control voltage-free and complete the remainder of the mechanical fitting as described in the "Instructions for Fitting, Operation and Maintenance, Roller Garage Door".

4. Set DIL switches 2-6 according to the additional functions (see section 4.3.2 - 4.3.5).

4.2 Factory reset

The operator has a power failure-proof memory in which the door-specific data (travel, forces needed during door travel, etc.) is stored during the teach-in process and updated during subsequent door travels. This data is only valid for this door. For use with another door, or if the door's travel behaviour has changed significantly (i.e. new springs, conversions etc.), this data must be deleted and the operator must be taught in again.

Reset and teach in the operator again

1. The door should be in the centre.
2. Push and hold down the RESET button for at least 5 seconds (see Figure 1.3), the rim of the large T button will flash quickly. When the rim of the large T button remains lit, release the RESET button.
All door data has been deleted. The rim of the large T button flashes 7x - pause - 7x - pause - etc. to show that the "operator has not been taught in yet".
3. Press the large T button 1x. The Open reference run takes place automatically, followed by two Close / Open cycles to teach in the Close end-of-travel position and the forces.
When the door stops in the OPEN end-of-travel position and the rim of the large T button flashes, the operator has been taught in.

WARNING
<p>Danger of injuries due to faulty safety equipment In the event of a malfunction, there is a danger of injuries due to faulty safety equipment.</p> <p>▶ After the learning runs, the person commissioning the door must check the function(s) of the safety equipment as well as the settings (see section 4.3).</p> <p>The system is ready for operation only after this.</p>

4.3 Setting additional functions via the DIL switches

Several of the operator's functions must be programmed using the DIL switches. Before initial start-up, the DIL switches are in factory settings, i.e. the switches are in the OFF position (see Figure 1.2).

DIL switches 1 to 6 (accessible under flap of operator cover, see Figure 1.1) must be set in accordance with the national regulations, the desired safety equipment and on-site circumstances.

Changes to the DIL switch settings are only permissible if the operator is idling and no pre-warning phase or automatic timer is active.

4.3.1 DIL switch 1

Set-up mode / press-and-hold operation and normal operation

▶ See section 4.1.2

1 ON	Activated, normal operation in press-and-release operation
1 OFF 	Not activated, set-up mode / press-and-hold operation for door fitting

4.3.2 DIL switch 2 / DIL switch 3

The functions of the operator (automatic timer / pre-warning phase) and the function of the option relay are set with **DIL switch 2** in combination with **DIL switch 3**.

Automatic timer, pre-warning phase

2 ON	3 ON	<p>Operator function After hold-open phase and pre-warning phase, automatic timer from the Open end-of-travel position (DIL switch 4 to ON)</p> <p>Operator light</p> <ul style="list-style-type: none"> • Permanent light during the hold-open phase and door run • Flashes quickly during the pre-warning phase <p>Option relay</p> <ul style="list-style-type: none"> • Permanent contact during the hold-open phase • Clocks rapidly during the pre-warning phase and slowly during door run
-------------	-------------	--



Close limit switch reporting

2 OFF 	3 ON	Operator light Permanent light during the door run / switch-off delay after end-of-travel positions have been reached
		Option relay Close limit switch reporting

Pre-warning time

2 ON	3 OFF 	Operator light Flashes quickly in the pre-warning phase Permanent light during the door run
		Option relay Relay clocks slowly during door run (function of an auto-flashing warning lamp)

External light

2 OFF 	3 OFF 	Operator light Permanent light during door run / switch-off delay after end-of-travel positions have been reached
		Option relay Same function as operator light (external light)

NOTE:

According to the DIN EN 12453 directive, the automatic timer must only become active if a safety device is connected.

NOTE:

Setting the automatic timer is only possible if the photocell is active. To do this, set **DIL switch 4** to **ON**.

When the door reaches the *OPEN* end-of-travel position and a hold-open phase of approx. 30 seconds has elapsed, the automatic timer will start. After an impulse or after the photocell has been passed, the remaining hold-open phase is stopped and set to a preset value (30 seconds).

4.3.3 DIL switch 4

Photocell (e.g. EL101, EL 301)

4 ON	Activated: if the photocell is activated, the door reverses to the <i>OPEN</i> end-of-travel position. The automatic timer can only be used with this setting (see section 4.3.2)
4 OFF 	Not activated, automatic timer not possible

4.3.4 DIL switch 5

Optional safety equipment (OSE)

5 ON	No closing possible without the safety equipment (OSE)
5 OFF 	Without safety equipment (OSE), normal door operation



4.3.5 DIL switch 6

Door maintenance display

6 ON	Activated; if the maintenance cycle is exceeded (see section 7.3), this is signalled by the operator light flashing several times at the end of every door run.
6 OFF 	Not activated, no signal after the maintenance cycle is exceeded

5 Radio

5.1 Hand transmitter HSM 4

	 WARNING
	<p>Danger of injury during door travel Persons may be injured by door travel if the hand transmitter is actuated.</p> <ul style="list-style-type: none"> ▶ Make sure that the hand transmitters are kept away from children and can only be used by people who have been instructed on how the remote-control door functions! ▶ If the door has only one safety device, only operate the hand transmitter if you are within sight of the door! ▶ Only drive or pass through remote control door systems if the door is in the <i>Open</i> end-of-travel position! ▶ Never stay standing under the open door. ▶ Please note that unwanted door travel may occur if a hand transmitter button is accidentally pressed (e.g. if stored in a pocket / handbag).

 CAUTION
<p>Danger of injuries due to unintended door travel Unintended door travel may occur while teaching in the radio system.</p> <ul style="list-style-type: none"> ▶ Make sure no persons or objects are in the door's area of travel when teaching in the radio system.

ATTENTION
<p>Malfunction due to environmental influences Non-compliance with these instructions can impair the function! Protect the hand transmitter from the following conditions:</p> <ul style="list-style-type: none"> • Direct sunlight (permissible ambient temperature: -20°C to +60°C) • Moisture • Dust

NOTES:

- If there is no separate garage entrance, perform all programming changes and extensions from inside the garage.

- After programming or extending the radio system, perform a function test.
- Only use original components when putting the radio system into service or extending it.
- Local conditions may affect the range of the radio system! Moreover, when used at the same time, GSM 900 mobile phones can affect the range.

5.1.1 Description of the hand transmitter HSM 4

▶ See Figure 12

- 1 LED
- 2 Hand transmitter buttons
- 3 Battery compartment cover
- 4 Battery
- 5 Reset button
- 6 Hand transmitter holder

5.1.2 Inserting / changing the battery

▶ See Figure 12

▶ Only use 23 A batteries

5.1.3 Resetting the factory code

▶ See Figure 12.2

A radio code is assigned to each hand transmitter button. The original factory code can be restored by performing the following steps.

NOTE:

The following steps are only required in the case of inadvertent extension or teach-in processes.

1. Open the battery compartment cover.
The small reset button (5) is accessible on the circuit board.

ATTENTION

Destruction of the button

- ▶ Do not use any pointed objects or excessive force when pressing the button.
2. Carefully press the reset button with a blunt object and keep it pressed.
3. Press the hand transmitter button to be coded and keep it pressed.
The sensor LED will flash slowly.
4. If you keep the small button pressed until the slow flashing stops, the original factory coding will be assigned to the hand transmitter button and the LED will start to flash faster.
5. Close the battery compartment cover.

The factory code has been reset.

5.2 Extending the remote control with additional hand transmitters HS 1, HS 4, HSM 4 or HSE 2

▶ See Figure 12.1

NOTE:

If there is no separate garage entrance, perform all programming changes and extensions from inside the garage.

1. Hold the transmitter that is supposed to "teach" the code (teaching transmitter **a**) directly next to the transmitter that is supposed to learn the code (learning transmitter **b**).
2. Press and hold the desired button on the teaching transmitter. The LED of the teaching transmitter will now light up continually.

3. Immediately afterwards press and hold the learning transmitter's button that you want to teach in – the learning transmitter's LED will first flash slowly for 4 seconds and then, if learning was successful, it will flash more quickly.
4. Release the buttons on both the teaching transmitter and the learning transmitter.

Carry out a function check! If a malfunction occurs, repeat steps 1-4.

CAUTION

Unintended door travel

Unwanted door travel may occur while programming the hand transmitter.

- ▶ When programming and extending the remote control, make sure no persons or objects are within the door's area of travel.

NOTE:

If the button on the learning transmitter is released while the LED is still flashing slowly, the teach-in process is cancelled.

5.2.1 Excerpt from the declaration of conformity for the hand transmitter

Conformity of the abovementioned product with the requirements of the directives according to article 3 of the R & TTE directives 1999/5/EC was verified by compliance with the following standards:

- EN 60950:2000
- EN 300 220-1
- EN 300 220-3
- EN 301 489-1
- EN 300 489-3

The original declaration of conformity can be requested from the manufacturer.

5.3 Integrated radio receiver

The roller garage door control is equipped with an integrated radio receiver. With the integrated radio receiver, the *Impulse* (Open / Stop / Close / Stop), *Light* (operator light on / off) and *Partial opening* (door only moves to a programmed height) functions can be programmed on max. 6 hand transmitters. If more than 6 hand transmitters are programmed, the first one programmed will be deleted without warning. All memory slots are empty in the delivery condition.

Radio programming / deleting data is only possible if the following applies:

- No set-up mode is activated (**DIL switch 1 to OFF**)
- No door run takes place.
- No pre-warning phase or hold-open phase is presently active

NOTE:

One of the hand transmitter buttons must be programmed on an integrated radio receiver to actuate the operator via radio. There must be a distance of at least 1 m between the hand transmitter and the control. When used at the same time, GSM 900 mobile phones can affect the range of the radio remote control.

5.4 Programming the hand transmitter buttons on an integrated radio receiver

- Briefly press the small **P** button (see Figure 1) once (for channel 1 = impulse command), twice (for channel 2 = light command) or three times (for channel 3 = partial opening command). Pressing the small **P** button again will immediately end radio programming. Depending on the channel being programmed, the rim of the large **T** button will flash 1x (for channel 1) or 2x (for channel 2) or 3x (for channel 3). During this time, a hand transmitter button can be programmed for the desired function.
- Press the hand transmitter button to be programmed until the rim of the large **T** button flashes rapidly. The radio code of this hand transmitter button is now stored in the integrated radio receiver.

5.5 Deleting all data in an integrated radio receiver

- Press and hold the small **P** button. The rim of the large **T** button flashes slowly, signalling the readiness for deletion. The flashing then becomes more rapid. Afterwards, the programmed radio codes of all hand transmitters are deleted.

5.5.1 Connecting an external radio receiver *

Instead of the integrated radio receiver, an external 1/2/3-channel radio receiver can be used for the *impulse* function (channel 1), *light* function (channel 2) and *partial opening* (channel 3) to control the roller garage door operator. Insert the plug of the receiver in the corresponding socket (see Figure 4). To avoid double assignments, delete the data of the integrated radio receiver when using an external radio receiver (see *Deleting all data in an integrated radio receiver*, page 29).

5.6 Excerpt from the declaration of conformity for the receiver

Conformity of the abovementioned product with the requirements of the directives according to article 3 of the R & TTE directives 1999/5/EC was verified by compliance with the following standards:

- EN 60950:2000
- EN 300 220-1
- EN 300 220-3
- EN 301 489-1
- EN 300 489-3

The original declaration of conformity can be requested from the manufacturer.

6 Operation

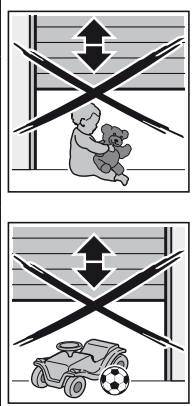
	⚠ WARNING
	<p>Danger of injury during door travel</p> <p>If people or objects are in the area around the door while the door is in motion, this can lead to injuries or damage.</p> <ul style="list-style-type: none"> Children are not allowed to play near the door system. Make sure that no persons or objects are in the door's area of travel. If the door has only one safety device, only operate the roller garage door operator if you are within sight of the door's area of travel. Monitor the door travel until the door has reached the end-of-travel position. Only drive or pass through remote control door systems if the door is in the Open end-of-travel position! Never stay standing under the open door.

⚠ CAUTION
<p>Danger of crushing in the side guide</p> <p>Do not reach into the side guide with your fingers during door travel, as this can cause crushing.</p> <ul style="list-style-type: none"> Do not reach into the guide rail during door travel.

ATTENTION
<p>Overloading the release knob</p> <p>The release knob can be damaged by overloading.</p> <ul style="list-style-type: none"> Do not hang on the release knob with your body weight.

6.1 Instructing users

- All persons using the roller garage door operator must be shown how to operate it properly and safely.
- Demonstrate and test the mechanical release as well as the safety reversal.

6.2 Function check

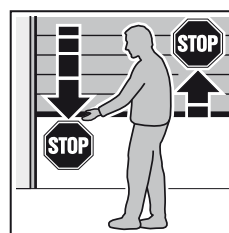

- To check the safety reversal, stop the door with both hands while it is closing. The door system must stop and initiate the safety reversal. The door system must also switch off and stop the door while it is opening.

* Accessory, not included as standard equipment!

6.3 Normal operation

In normal operation, the garage door operator works exclusively according to the impulse sequence control. It does not matter whether an external button, a programmed hand transmitter button or the large **T** button has been actuated:

- 1st impulse: The door runs towards an end-of-travel position.
- 2nd impulse: The door stops.
- 3rd impulse: The door runs in the opposite direction.
- 4th impulse: The door stops.
- 5th impulse: The door runs in the direction of the end-of-travel position selected during the 1st impulse.

etc.

The operator light will light up during a door run and go out approx. 2 minutes after the door run ends.

6.4 Partial opening

The partial opening function (ventilation position) can only be controlled via the internal / external radio.

- Using impulse control, move the door to the desired position
- On the control, teach in a hand transmitter button for **channel 3** (see section 5.4).

6.5 Operator light

The operator light will light up during a door run and go out approx. 2 minutes after the door run ends.

Via the radio remote control (**channel 2**, see section 5.4), the operator light can be switched on or off when the operator is idling. The maximum illumination time is automatically set to 5 minutes.

6.6 Mains failure bridging using an emergency battery HNA 18 *

To enable door movement in the event of a mains failure, an optional emergency battery HNA 18 can be connected (see Figure 9.1a).

1. Pull out the mains plug or, in the case of a fixed connection, disconnect the current supply
2. Remove plug cover and top part of housing.
3. Insert the plug of the emergency battery HNA 18 into the corresponding socket.
4. Refasten the half of the housing.
5. Connect the mains plug (reconnect the power supply)
The operator light will flash three times (see section 7.2).
The next run will be an *Open* reference run.

In the case of a mains failure, the system automatically switches to battery operation. During battery operation, the operator light remains switched off.

NOTE:

Only use emergency battery HNA 18 with integrated charging circuit, which is intended for this purpose.

6.7 Operation after the decoupling mechanism (mechanical release) has been actuated

The decoupling mechanism separates the operator from the shaft. This means that the door can be opened manually, e.g. during a power failure.

Interior roller garage door operator (IR)

- ▶ See Figure 13a

ATTENTION
<p>Overloading the release knob</p> <p>The release knob can be damaged by overloading.</p> <ul style="list-style-type: none"> ▶ Do not hang on the release knob with your body weight.

1. Pull the release knob and lead the cable clamp under the hook on the housing in order to mechanically release the operator.
After releasing, the rim of the large **T** button will flash 8x.
2. Open or close the door.
3. After manual use, lock the decoupling mechanism using the release knob.
4. Press the large **T** button once.
The door moves with reduced speed towards the *OPEN* end-of-travel position in order to set the home position (reference run).
5. The rim of the large **T** button illuminates; the operator is now ready for normal operation again.

Exterior roller garage door operator (AR)

- ▶ See Figure 13b

ATTENTION
<p>Overloading the manual release</p> <p>The manual release may be damaged if it is overloaded.</p> <ul style="list-style-type: none"> ▶ Do not hang on the manual release.

1. Pull the release handle down and hold the handle.
2. Fold the fixing upwards and slide the cable into the slot of the fixing.
After releasing, the rim of the large **T** button will flash 8x.
3. Open or close the door.
4. After manual use, lock the decoupling mechanism using the manual release.
5. Press the large **T** button once.
The door moves with reduced speed towards the *OPEN* end-of-travel position in order to set the home position (reference run).
6. The rim of the large **T** button illuminates; the operator is now ready for normal operation again.

NOTE:

The mechanical release function must be inspected **monthly**. The release may only be actuated when the door is closed; otherwise, there is a danger that the door will close rapidly if the springs are weak, broken or defective or if the counterbalance is inadequate.

7 Operator light

7.1 Operator light

The operator light will illuminate during a door run and go out approx. 2 minutes after the door run ends.

Via the radio remote control (**channel 2**, see section 5.4), the operator light can be switched on or off when the operator is idling. The maximum illumination time is automatically set to 5 minutes.

* Accessory, not included as standard equipment!

7.2 Messages when mains voltage is on

If the mains plug is plugged in and the large **T** button is not pushed, the operator light will flash two or three times.

If it flashes two times, this shows that no door data is present or that the door data has been deleted (as in delivery condition); it can then be taught in immediately.

If it flashes three times, this signals that saved door data is present, but the last door position is not sufficiently known. For this reason, the next run will be in the *OPEN* direction with decreased speed (reference run). Door travel in normal operation will follow.

7.3 Maintenance display

If **DIL switch 6** is set to **ON**, the operator light will flash several times after each door travel, to show that door maintenance is due, if:

- over 2000 door cycles were run after each learning cycle
- over one year of operating time has elapsed since the last maintenance.

8 Operation, error and warning messages

Error messages / diagnostic LED

The diagnostic LED (see Figure 1), which is visible through the rim of the large **T** button, helps to easily identify causes when the operator doesn't work according to specifications. In a taught-in condition, the LED is constantly illuminated and goes out as soon as an externally connected impulse is present.

An error is shown by flashing:

LED flashes quickly
Press-and-hold operation for setting up the operator (DIL-1, see section 4.1/4.3.1)
LED flashes 2x
Possible cause Photocell was interrupted / not connected
Remedy Check photocell, replace or connect as necessary
LED flashes 3x
Possible cause The <i>Close</i> power limit has been activated – a safety reversal took place.
Remedy Remove the obstacle. If the safety reversal took place for no apparent reason, check the door mechanism. If necessary, delete the door data and teach it in again.
LED flashes 4x
Possible cause The static current circuit (RSK, see section 3.4) is open or was opened during a door run.
Remedy Check the connected units, close the circuit.

LED flashes 5x
Possible cause The <i>OPEN</i> power limit has been activated – the door was stopped during an opening run.
Remedy Remove the obstacle. If the door stopped before the <i>OPEN</i> end-of-travel position for no apparent reason, check the door mechanism. If necessary, delete the door data and teach it in again.
LED flashes 6x
Possible cause Operator error / malfunction in operator system
Remedy If necessary, delete the door data. If the operator error occurs again, the operator should be replaced.
LED flashes 7x
Possible cause The operator has not been taught in yet (this is only a message and not a malfunction).
Remedy Activate the learning cycle via the large T button.
LED flashes 8x
Possible cause Power failure or mechanical release. The operator requires an <i>OPEN</i> reference run.
Remedy Trigger the <i>Open</i> reference run with an external button, the hand transmitter or the large T button.
LED flashes 13x
Possible cause Voltage of emergency battery HNA 18 is too low
Remedy Further electrical operation is possible only after the mains voltage has been restored.
LED flashes 14x
Possible cause Connection to the motor connection circuit board in the operator is defective.
Remedy Check the connection and the connecting cables, exchange the motor connection circuit board.

9 Inspection and Maintenance

The roller garage door operator is maintenance-free.

In the interest of your own safety, we recommend having the door system inspected and maintained by a qualified person in accordance with the manufacturer's specifications.

 WARNING	
Danger of injury due to unexpected door travel	
Unexpected door travel can occur during inspection and maintenance work if the door system is inadvertently actuated by other persons.	
▶	Disconnect the mains plug or, with a permanent connection, <ul style="list-style-type: none"> – (see section 3.2.1) turn off the system power. – and disconnect the emergency battery HNA 18 if needed.
▶	Prevent the door system from being switched on again without authorisation in accordance with the safety regulations.



Inspection and repairs may only be carried out by a qualified person. Contact your supplier for this purpose.

A visual inspection may be carried out by the operator.

- ▶ Check all safety and protective functions **monthly**.
- ▶ Any malfunctions and/or defects must be remedied **immediately**.

9.1 Replacement bulb

For replacing the operator light:

	 DANGER
Mains voltage	
If the light is switched on, mains voltage is present at the lamp socket.	
▶	Exchange the light bulb only if the operator is voltage-free.

 CAUTION	
Hot light bulb	
Touching the light bulb during or immediately following operation can lead to burns.	
▶	Do not touch the light bulb if it is switched on or was recently switched on.

1. Pull out the mains plug or, in the case of a permanent connection (see section 3.2.1), turn off the system power
2. Remove the lamp cover (see Figure 14)
3. Replace the light bulb (candle bulb E14 matt, 240 V / max. 25 W)
4. Fit the lamp cover
5. Connect the mains plug (reconnect the power supply)
The operator light will flash three times (see section 7.2).
The next run will be an *Open* reference run.

10 Optional accessories

Optional accessories are not included in the scope of delivery.

Loading of the operator by all electrical accessories:
max. 100 mA.

The following accessories are available:

- Option relay for warning lamp
- External radio receivers
- External impulse buttons (e.g. key switches)
- One-way photocell
- Battery pack for emergency power supply
- Signal tone generator for forced opening attempt
- External release

11 Dismantling and Disposal



NOTE:

When dismantling the door, observe the applicable regulations governing occupational safety.

Have a specialist dismantle the control in the reverse order of these instructions and dispose of it properly.

Electrical and electronic devices as well as batteries may not be disposed of in household rubbish. They must be disposed of at the appropriate recycling facilities.

12 Warranty Conditions

Warranty

We shall be exempt from our warranty obligations and product liability in the event that the customer carries out his own structural alterations or undertakes improper installation work or arranges for same to be carried out by others without our prior approval and contrary to the fitting guidelines we have provided. Furthermore, we will assume no responsibility for the accidental or careless operation of the operator and accessories, nor for improper maintenance of the door and its counterbalance. Batteries are also not covered by the warranty.

Warranty period

In addition to the statutory warranty provided by the dealer in the sales contract, we grant the following warranty for parts from the date of purchase:

- 5 years for the operator mechanics, motor and motor control
- 2 years on radio equipment, accessories and special systems

There is no warranty on consumables (e.g. fuses, batteries, lamps). Claims made under the warranty do not extend the warranty period. For replacement parts and repairs the warranty period is six months or at least the remainder of the warranty period.

Prerequisites

The warranty claim only applies in the country where the equipment was purchased. The product must have been purchased through our authorised distribution channels. A claim under this warranty exists only for damage to the object of the contract itself. Reimbursement of expenditure for dismantling and fitting, testing of parts as well as demands for lost profits and compensation for damages are excluded from the warranty.

The receipt of purchase substantiates your right to claim under the warranty.

12.1 Performance

For the duration of the warranty we shall eliminate any product defects that are proven to be attributable to a material or manufacturing fault. We pledge to replace free of charge and at our discretion the defective goods with non-defective goods, to carry out repairs or to grant a price reduction.

Damages caused by the following are excluded:

- improper fitting and connection
- improper initial start-up and operation
- external factors such as fire, water, abnormal environmental conditions
- mechanical damage caused by accidents, falls, impacts
- negligent or intentional destruction
- normal wear or deficient maintenance
- repairs conducted by unqualified persons
- use of non-original parts
- removal or defacing of the data label

Replaced parts become our property.

13 Excerpt from the Declaration of Incorporation

(as defined in EC Machinery Directive 2006/42/EC for incorporation of partly completed machinery according to annex II, part B).

The product described on the reverse side has been developed, constructed and produced in accordance with:

- EC Machinery Directive 2006/42 EC
- EC Construction Products Directive 89/106/EEC
- EC Low-Voltage Directive 2006/95/EC
- EC Electromagnetic Compatibility Directive 2004/108/EC

Applied and consulted standards:

- EN ISO 13849-1, PL “c”, Cat. 2
Safety of machinery – Safety-related parts of control systems – Part 1: General principles
- EN 60335-1/2, when applicable
Safety of electrical appliances / Operators for doors
- EN 61000-6-3
Electromagnetic compatibility – Electromagnetic radiation
- EN 61000-6-2
Electromagnetic Compatibility – Interference immunity

Partly completed machinery as defined in the EC Directive 2006/42/EC is only intended to be incorporated into or assembled with other machinery or other partly completed machinery or equipment, thereby forming machinery to which this directive applies.

This is why this product must only be put into operation after it has been determined that the entire machine / system in which it was installed corresponds with the guidelines of the EC directive mentioned above.

14 Technical data

External dimensions:	275 x 140 x 90 mm
Mains voltage:	230/240 V, 50/60 Hz, stand-by approx. 6 W
Protection category:	Only for dry rooms
Temperature range:	-20°C to +60°C
Replacement bulb:	Candle bulb E14, 240 V, max. 25 W
Fuse for control current circuit:	Microfuse 5 x 20 mm, 2 A
Motor:	Direct current motor with hall sensor
Transformer:	With thermal protection
Connection:	No-screw connection technology for external equipment with 24 V DC low safety voltage, such as internal and external buttons with impulse operation.
Remote control:	Operation with internal or external radio receiver
Automatic cut-out:	Is automatically taught in for both directions separately. Self-learning, wear-free, as it has no mechanical switches.
Travel / power limit	Readjusting automatic safety cut-out for every door run.
Door travel speed:	Approx. 11 cm/s (depending on door size, door weight and barrel diameter)
Rated load:	See data label
Pull and push force:	See data label
Short-term peak load:	See data label
Special functions:	<ul style="list-style-type: none"> • Operator light, 2-minute light ex factory • Photocell can be connected • Option relay for warning lamp • Signal tone generator for forced opening attempt • Battery can be connected for emergency operation • External release
Emergency release:	Actuated from inside with pull cord in the event of a power failure
Airborne sound emission of the garage door operator:	≤ 70 dB (A)
Door cycles:	See product information

15 Overview of DIL switch functions

DIL 1		Set-up mode / press-and-hold operation and normal operation
OFF	Not activated, set-up mode / press-and-hold operation for door fitting	
ON	Activated, normal operation in press-and-release operation	







Automatic timer, pre-warning phase						
DIL 2	DIL 3	DIL 4	Operator function	Operator light function	Option relay function	
OFF	OFF	OFF	–	Permanent light during the door run / switch-off delay after end-of-travel positions have been reached	Same function as operator light (external light)	
ON	OFF	OFF	–	<ul style="list-style-type: none"> Flashes quickly in the pre-warning phase Permanent light during the door run 	Relay clocks slowly during the door run (function of an auto-flashing warning lamp)	
OFF	ON	OFF	–	Permanent light during the door run / switch-off delay after end-of-travel positions have been reached	Close limit switch reporting	
ON	ON	ON	Automatic timer	<ul style="list-style-type: none"> Permanent light during the hold-open phase and the door run Flashes quickly during the pre-warning phase 	<ul style="list-style-type: none"> Permanent contact during the hold-open phase Clocks rapidly during the pre-warning phase and slowly during the door run 	

DIL 4		Photocell (e.g. EL 101, EL 301)
OFF	Not activated, automatic timer not possible	
ON	Activated, if the photocell is activated, the door reverses to the <i>OPEN</i> end-of-travel position. Automatic timer is only possible with this setting.	

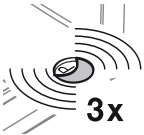
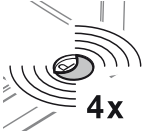
DIL 5		Optional safety equipment (OSE)
OFF	Without safety equipment (OSE), normal door operation	
ON	No closing possible without the safety equipment (OSE)	

DIL 6		Door maintenance display
OFF	Not activated, no signal after the maintenance cycle is exceeded	
ON	Activated; if the maintenance cycle is exceeded, this is signalled by the operator light flashing several times at the end of every door run.	

16 Overview of errors and troubleshooting

Display	Error / warning	Possible cause	Remedy
	Safety equipment	Photocell was interrupted, is not connected.	▶ Check photocell, replace or connect as necessary (see Figure 8).
	Power limit in <i>Close</i> direction	Obstacle in door area.	▶ Remove the obstacle. ▶ Delete any door data and teach in again (see section 4.2).
	Static current circuit	The static current circuit (RSK, see section 3.4) is open.	▶ Check the connected units, close the circuit (see section 3.4).
	Power limit in <i>OPEN</i> direction	Obstacle in door area.	▶ Remove the obstacle. ▶ Delete any door data and teach in again (see section 4.2).
	Operator error	Malfunction in operator system	▶ Delete door data, replace operator if this recurs several times (see section 4.2).
	Operator error Message, no fault	The operator has not been taught in yet.	▶ Teach in the operator (see section 4.1.2).
	No reference point Power failure, mechanical locking	The operator requires an <i>Open</i> reference run.	▶ Reference run in the <i>Open</i> direction (see section 6.7).
	Emergency battery voltage	Voltage of emergency battery is too low.	▶ Further electrical operation is possible only after the mains voltage has been restored (see section 3.3.5).
	Connecting cables	Connection to the motor connection circuit board in the operator is defective.	▶ Check the connection and connection cables. ▶ Exchange the motor connection circuit board.

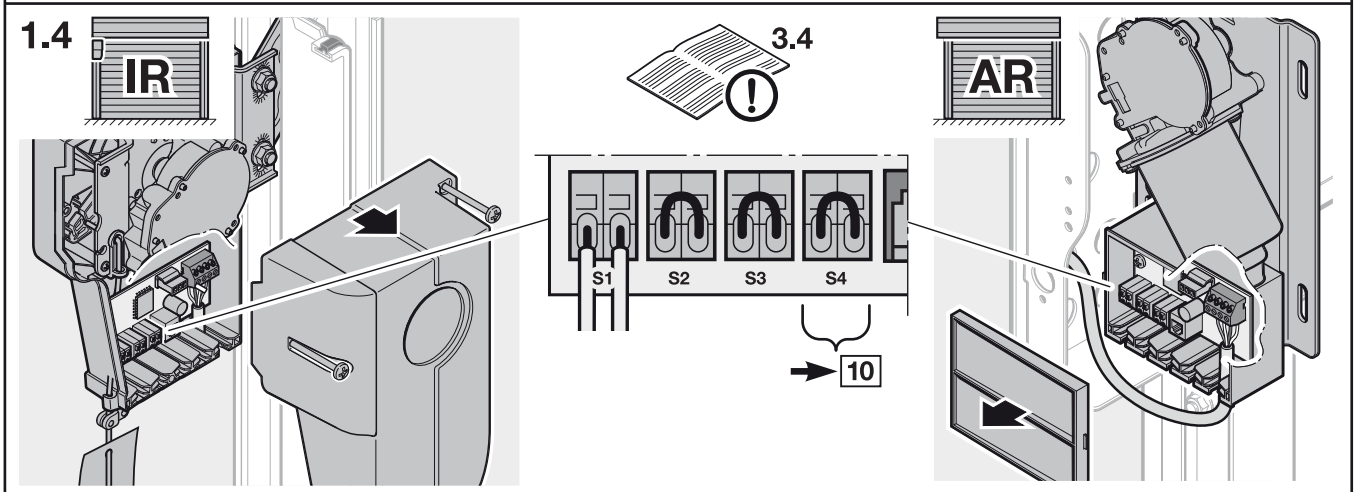
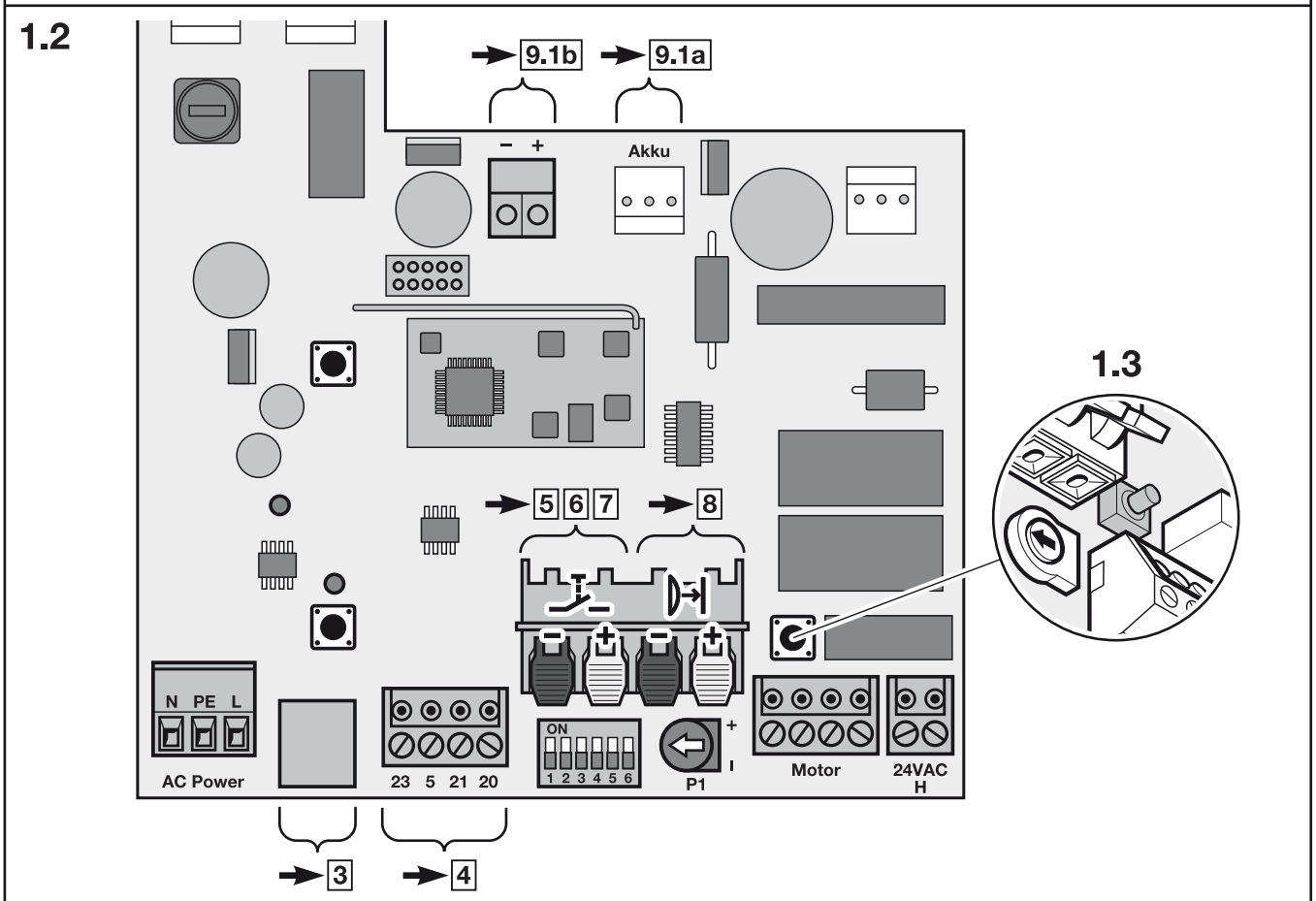
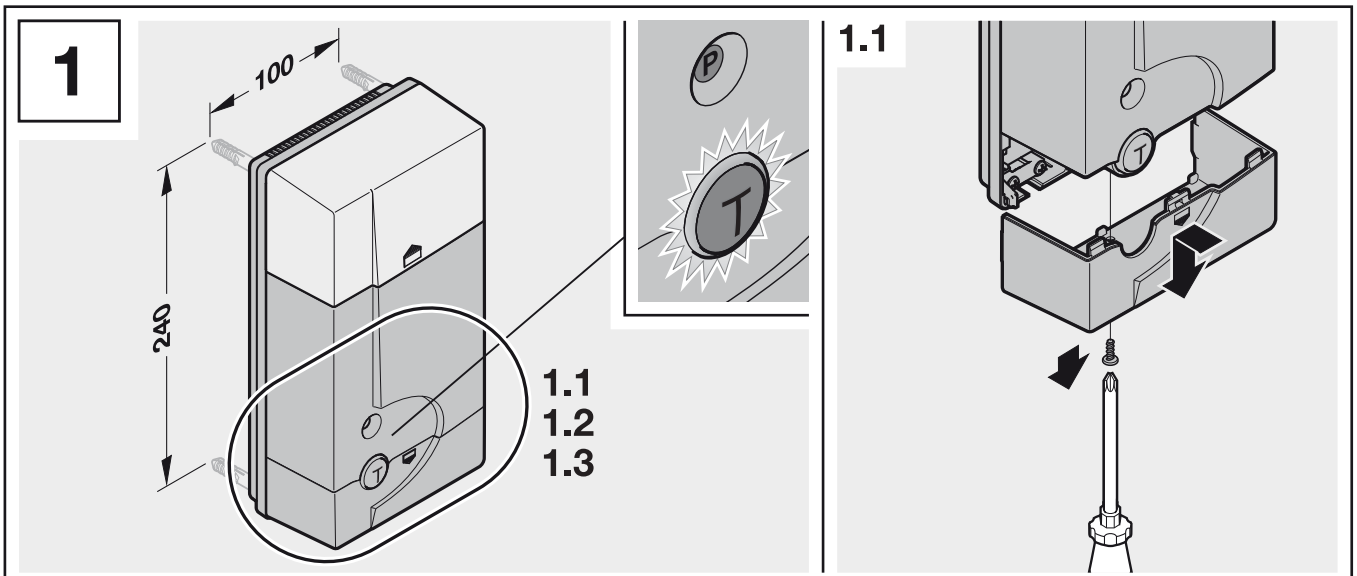

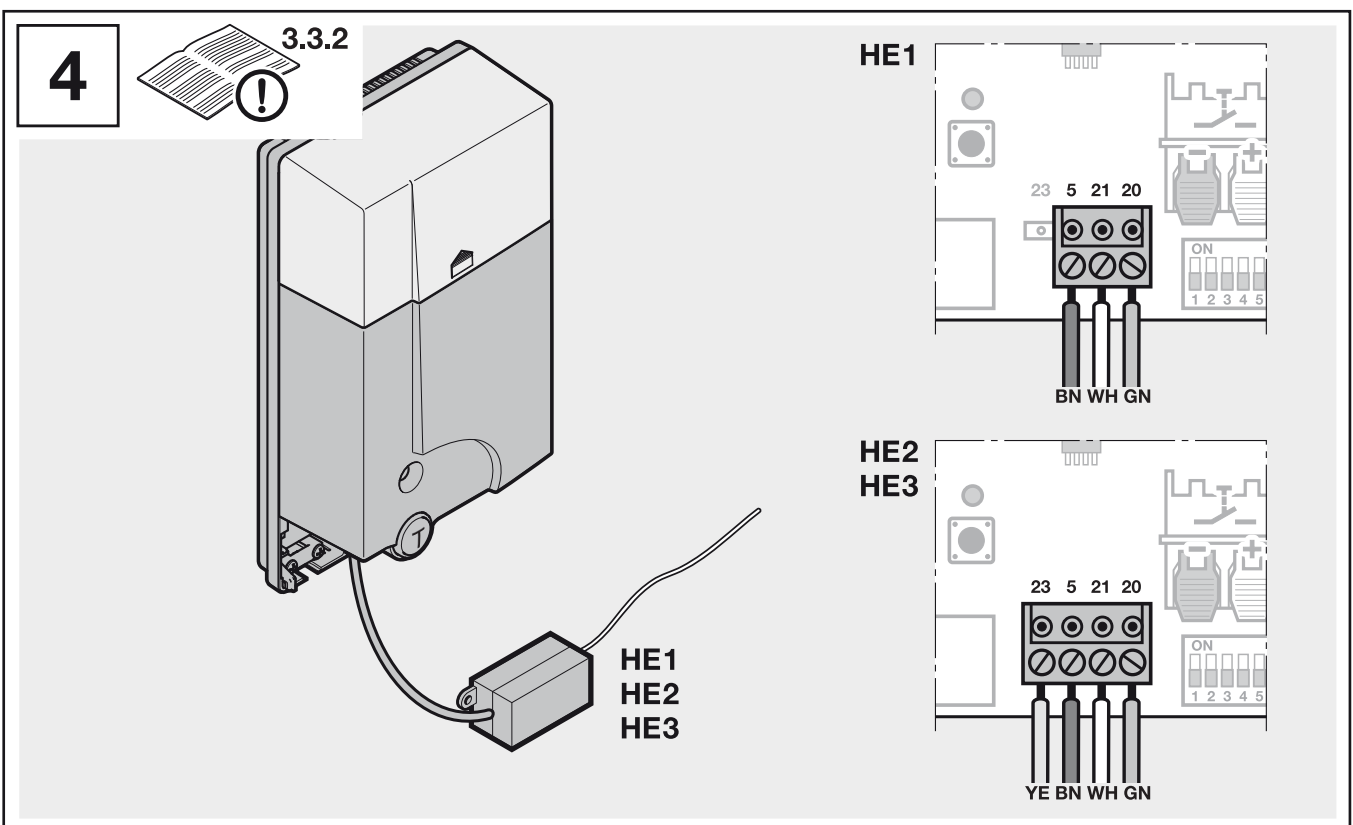
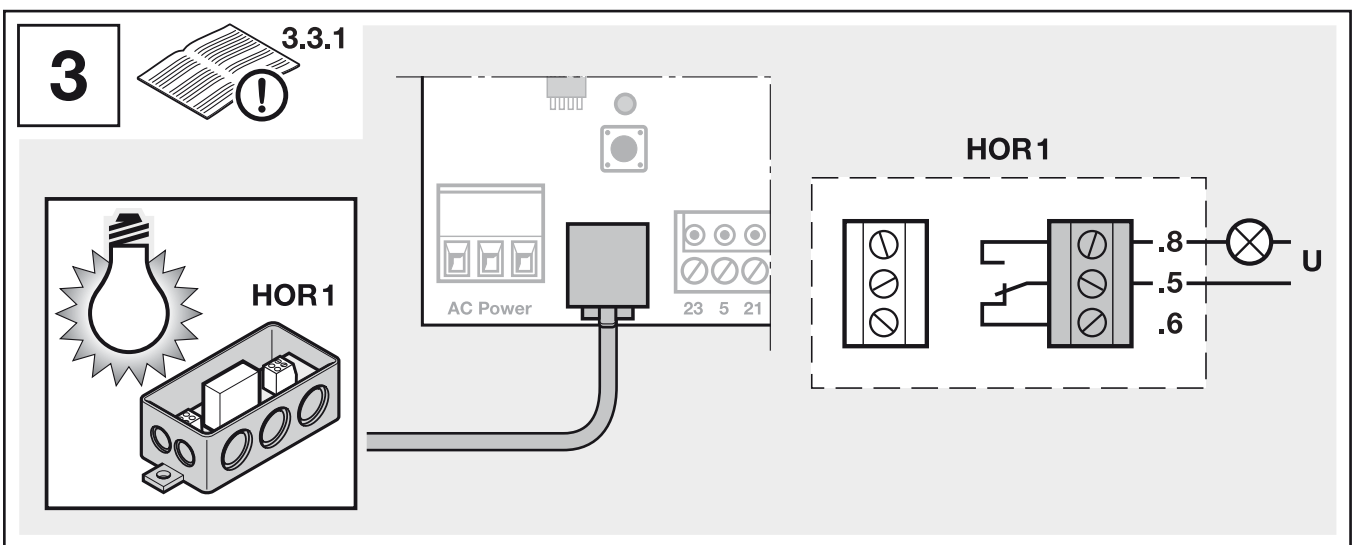
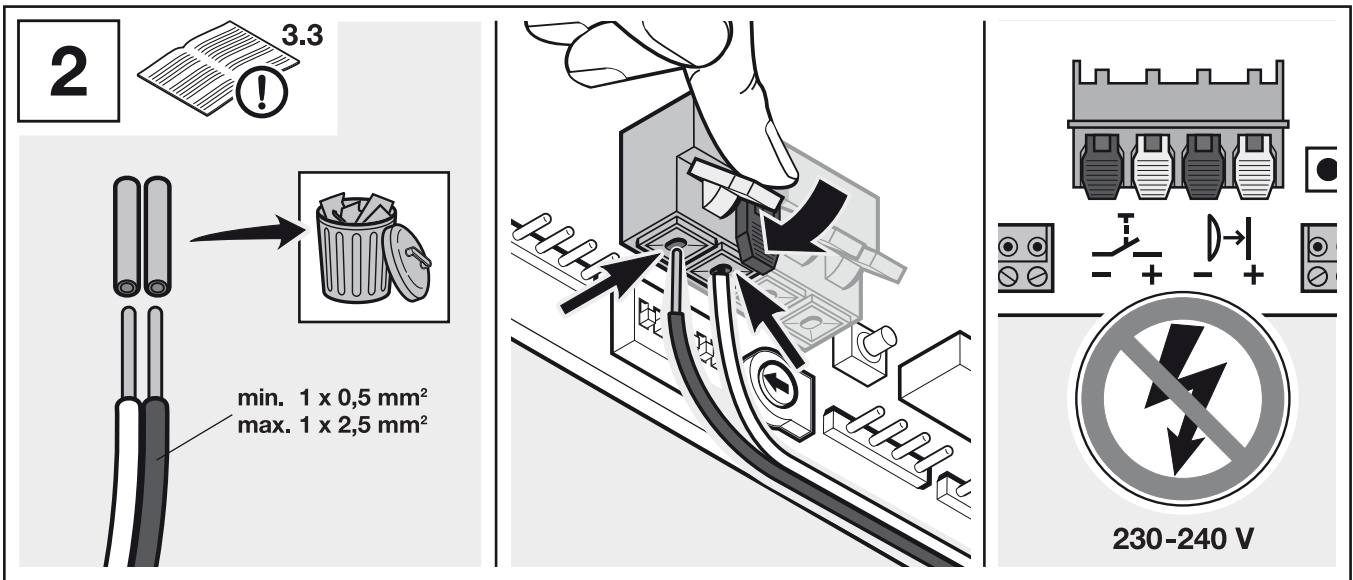

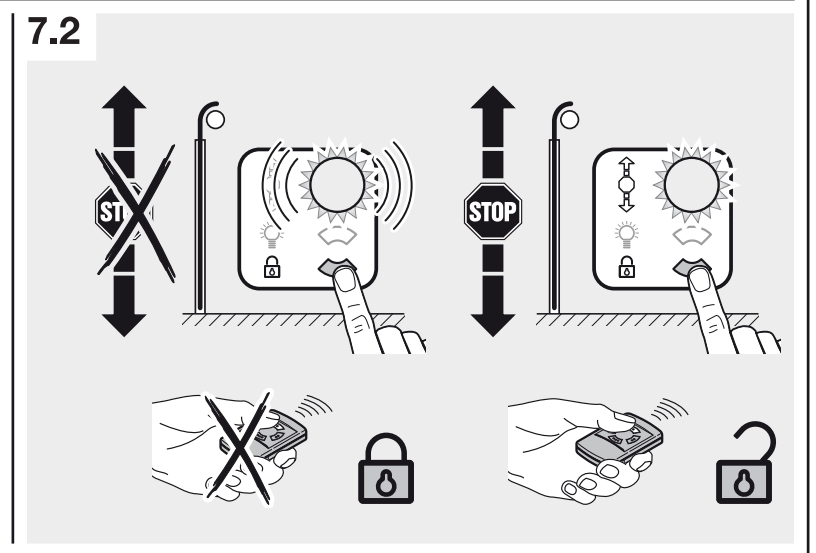
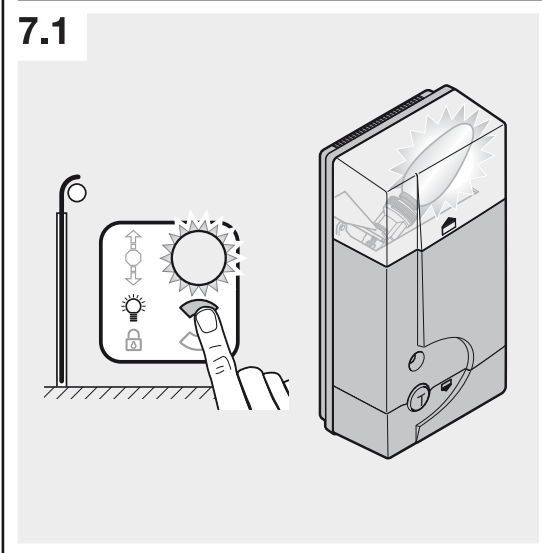
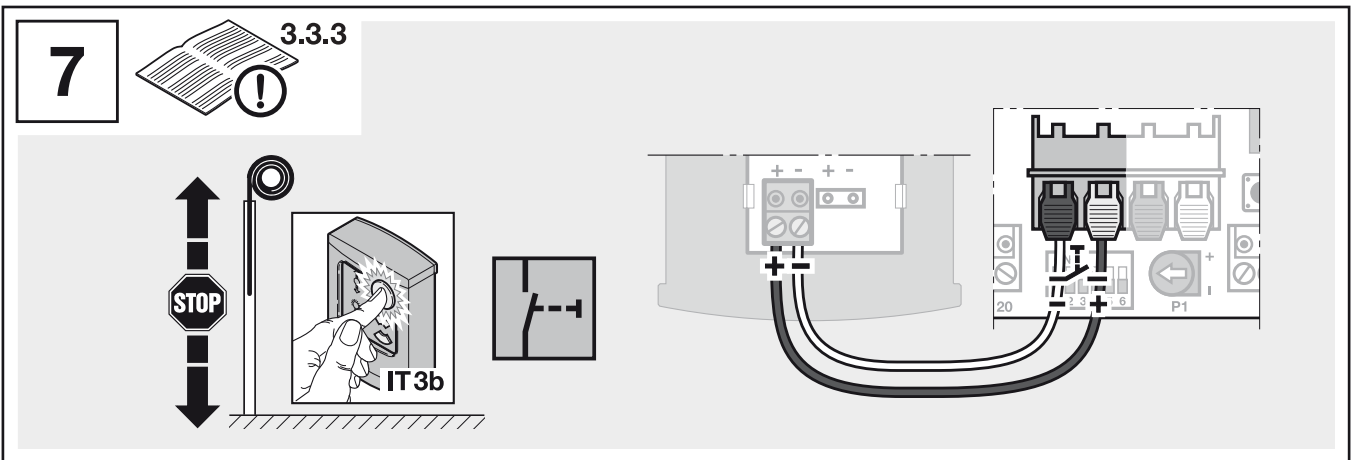
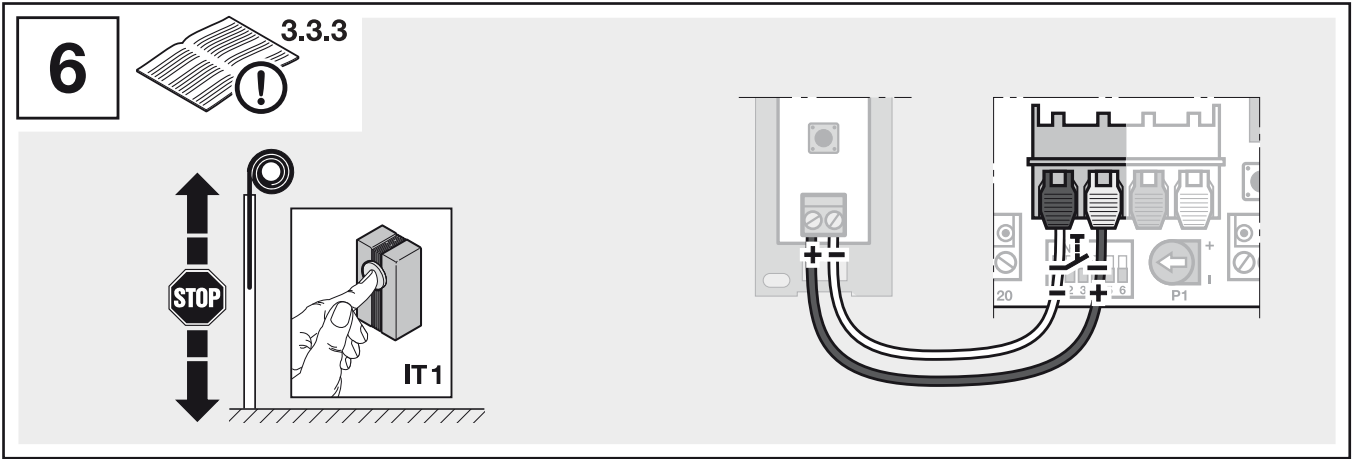
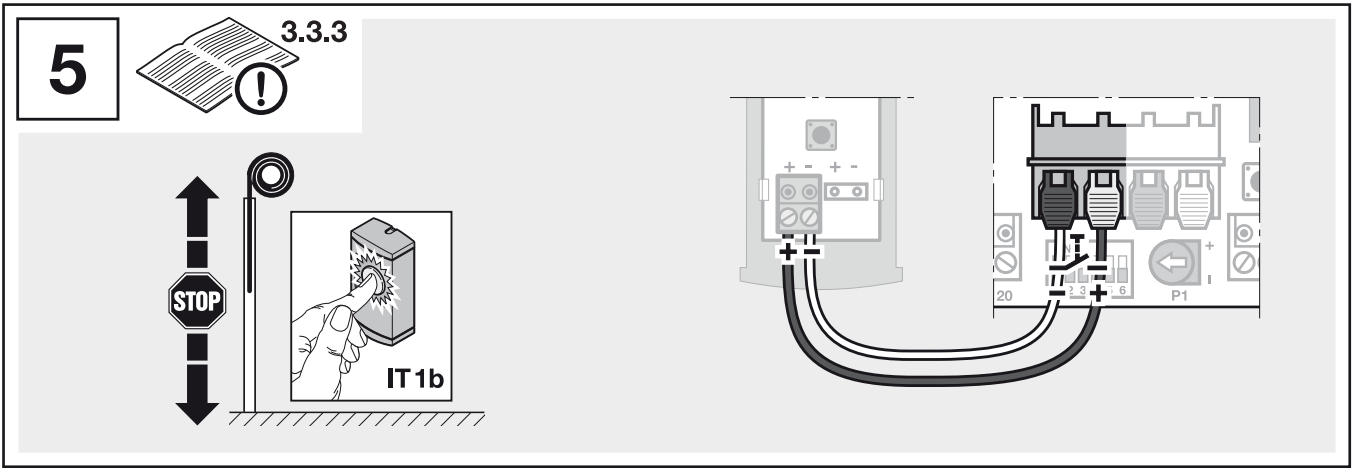

8

3.3.4

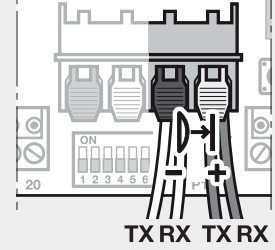
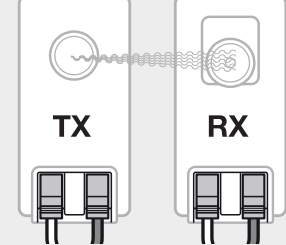
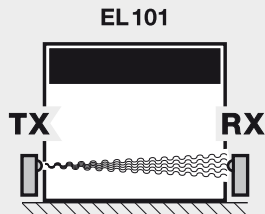
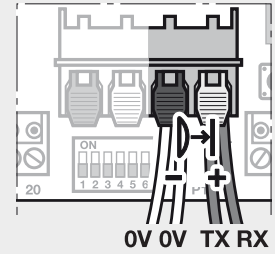
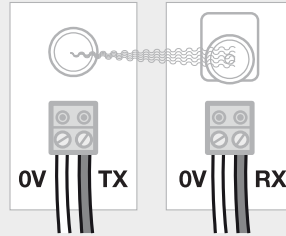
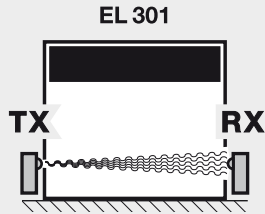
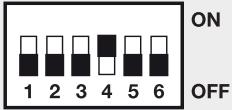

9

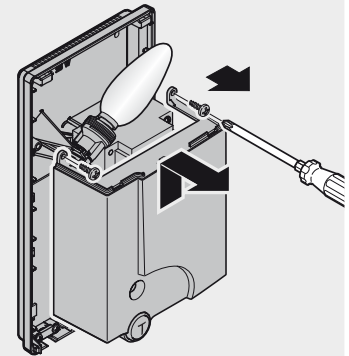
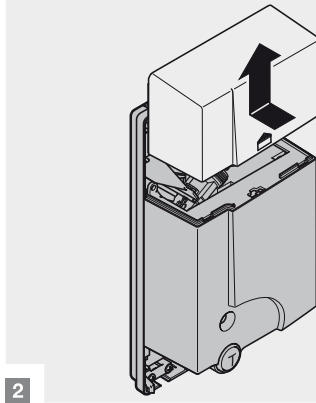
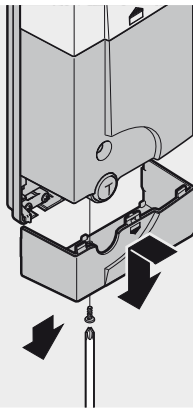

9.1a 3.3.5

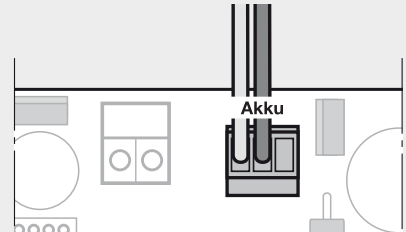
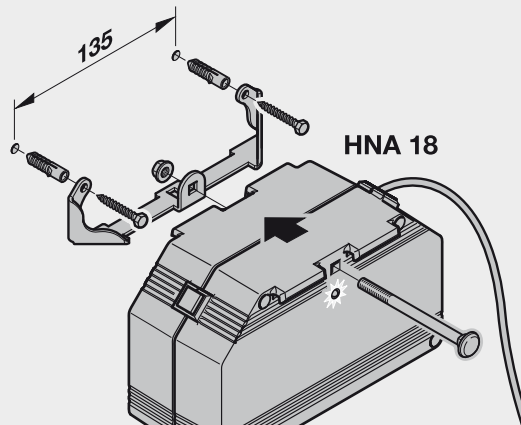

9.1b 3.3.6

