

 HomeLink®

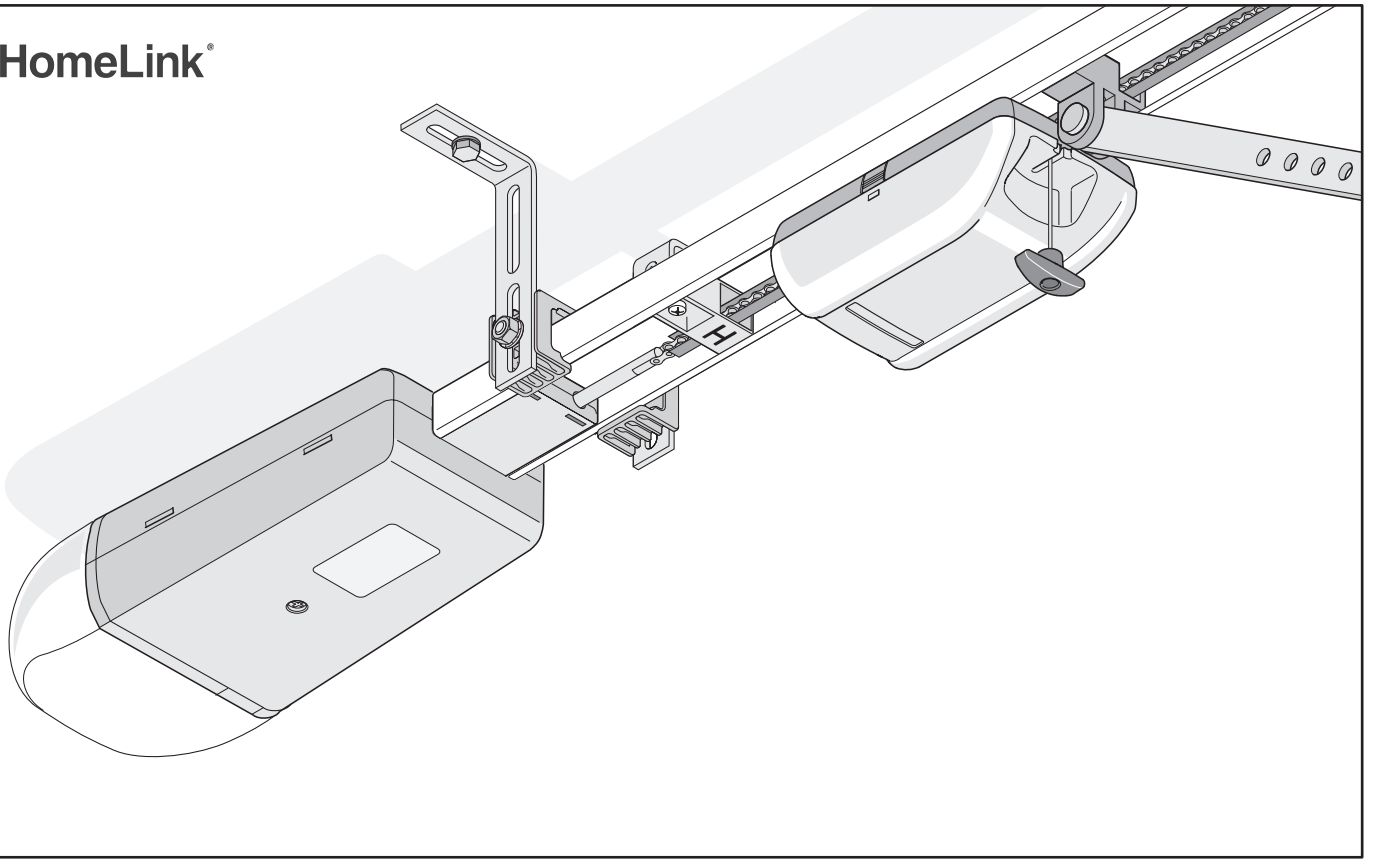

sprint evolution

GB Installation and operating instructions

1 - 25



Contents

General information	3	Functions and connections	19
Symbols	3	General information.....	19
Safety instructions.....	3	Obstacle recognition (DIP 1, 2 + 3).....	19
General	3	Drive behaviour upon opening the door.....	19
Storage	3	Drive behaviour upon closing the door	19
Operation	3	Connecting light barrier	19
Radio remote control	3	Connecting push-button 2 (DIP 2).....	19
Rating plate.....	3	Connecting warning lamp (DIP 4)	19
Normal use.....	3	Direct socket unit (push-button 1)	20
Maximum door dimensions.*	4	Early warning time (DIP 5)	20
Technical data	4	Backjump (DIP 6).....	20
EU conformity declaration	4	Defined opening and closing (DIP 7).....	20
Declaration of Installation.....	5	Partial opening (DIP 8).....	20
Scope of delivery.....	6	Connecting an external aerial	21
Preparations for installation.....	7	TorMinal interface.....	21
Safety instructions.....	7	Trolley board	21
Tools required.....	7	Maintenance and care	22
Personal protective equipment.....	7	Important information	22
Installing a wicket door safety facility or release lock.....	7	Cleaning chain and drive unit rail	22
Installation.....	8	Changing bulbs	22
Safety instructions.....	8	Changing fuses (connecting warning lamp).....	22
Door types and special accessories*	8	Regular checks	23
Installation tips	8	Miscellaneous	24
Pre-installation	9	Disassembly.....	24
Installation.....	10	Disposal	24
Fitting and connecting push-buttons	12	Warranty and after-sales service	24
Installing the socket outlet.....	12	Troubleshooting	25
Commissioning.....	13	Further troubleshooting tips	25
Safety instructions.....	13		
Setting door OPEN + CLOSED end positions	13		
Teaching in drive	13		
Checking emergency release.....	14		
Checking force setting.....	14		
Programming of hand-held transmitter.....	14		
Attaching instruction label	14		
Attaching warning sign	15		
Operation / handling.....	16		
Safety instructions.....	16		
Opening door	16		
Closing door	16		
Pulse sequence of door movement.....	16		
Emergency release	16		
Control reset.....	16		
Interim stop	17		
Safety stop 1 (force cut-off)	17		
Safety stop 2 (safety input).....	17		
Overload protection.....	17		
Operation following a power failure.....	17		
Radio remote control receiver	17		
Safety instructions	17		
Description of display and push-buttons.....	17		
Programming of hand-held transmitter	18		
Deleting the hand-held transmitter key from the radio receiver.....	18		
Deleting a channel from the radio receiver.....	18		
Clearing radio receiver memory.....	18		
Connecting an external aerial	18		
What is push-button 2 used for?	18		

General information

Symbols



CAUTION SYMBOLS:

Indicates a potential risk! Failure to follow instructions may result in serious injuries or damage!



NOTE SYMBOLS:

Information, useful advice!



Refers to the relevant illustration in the introduction or main text.

Safety instructions

General

- These installation and operating instructions must be read, understood and observed by the person who is installing, operating or maintaining the system.
- Installation, connection and initial operation of the drive mechanism may only be carried out by qualified specialists.
- Only install the drive mechanism to correctly aligned and weight-balanced doors. An incorrectly aligned door could cause serious injury or damage to the drive mechanism.
- The manufacturer cannot be made liable for any damage or disruptions to operation occurring due to non-compliance with the installation and operating instructions.
- Ensure that these installation and operating instructions are located in an easily accessible place in the garage.
- Observe and comply with the locally applicable accident prevention regulations and standards.
- Observe and comply with the directive on 'Power-driven Windows, Doors and Gates - BGR 232' issued by the Employers' Liability Insurance Association. (valid for the given user in Germany)
- Always disconnect the drive mechanism from the power supply before carrying out any work.
- Only use the manufacturer's original spare parts, accessories and fixing material.

Storage

- The drive mechanism may only be stored indoors, in a dry, sealed environment at an ambient temperature of between -20°C and +50°C.
- The drive mechanism should be stored horizontally.

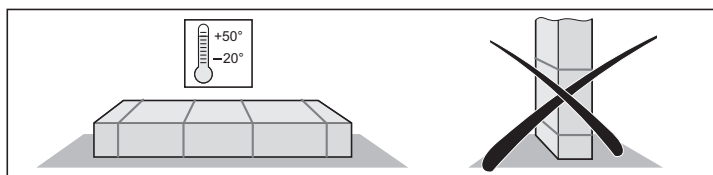

Operation

- The drive mechanism may only be operated after a risk-free force tolerance has been set. Select the lowest possible force tolerance to reduce the risk of injury.
- Keep your hands clear of any moving door or any moving parts.
- Keep children, disabled persons and animals away from the door.
- Only drive into and out of the garage when the door is fully opened.
- Risk of persons trapping or cutting themselves in/on the door system's moving parts or edges where it closes.

- If the door is not equipped with a small, flap door, or if there is no alternative access to the garage, install an emergency release system (emergency release lock or control cable) that can be activated from the outside.

Radio remote control

- The radio remote control may only be used for equipment and systems in which defective remote operation of the transmitter or radio receiver does not constitute a risk to people, animals or property, or in cases where this risk is eliminated by means of additional safety facilities.
- The user must be made aware of the fact that the remote control of equipment with accident risk potential may only occur, if at all, when the equipment concerned is clearly visible.
- Radio remote control may only be used if movement of the door can be supervised and there are no persons or objects in the area of movement.
- Store the manual remote control in such a way that there is no risk of it being accidentally operated by, for instance, children or animals.
- The operator of this radio-controlled equipment is in no way protected from interference from other telecommunications systems and facilities (e.g. other radio-controlled equipment that is licensed to operate at the same frequency range). If serious interference is encountered, please contact your nearest telecommunications office with interference measuring facilities (radio signal localisation)!
- Do not use the manually-operated remote control near locations or installations that are susceptible to radio interference (airports, hospitals).

Rating plate

- The rating plate is located on the cover of the control housing.
- Exact type designation and date of manufacture (month/year) of the drive can be found on the rating plate.

Normal use



CAUTION! RISK OF SERIOUS DAMAGE TO DRIVE!

Do not open or close the door with the drive system without first adjusting the balance weight (springs tensions). Otherwise, the motor (gear system) might be seriously damaged.



CAUTION! RISK TO LIFE AND LIMB!

Remove all ropes and loops that are required for the manual operation of the door.

- The drive is designed for the exclusive purpose of opening and closing doors. Any other use does not constitute normal use. The manufacturer accepts no liability for damage resulting from use other than normal use. The user accepts sole responsibility for any risk thereby incurred. The warranty ceases to apply in this case.
- Doors operating automatically with a drive must comply with the standards and directives valid at the given time: e.g. EN 12604, EN 12605.
- The drive system may only be operated if it is in proper working order. Always follow standard safety procedures and adhere to the instructions in this installation and operating manual.
- Any defects that may impair the safe operation of the equipment should be eliminated without delay.
- The door must be stable and twist-proof, i.e. it should not bend or twist during opening or closing operations.
- The drive mechanism is unable to compensate for any defects in the door or for its incorrect installation.
- Only use the drive mechanism in a dry, indoor environment where there is no risk of explosion.
- Do not use drive in rooms where a hostile environment prevails (e.g. salty air).

General information

Maximum door dimensions.*

		Unit
Maximum width		
Up-and-over-door	4000	mm
Sectional door	4000	mm
Side hinged door **	2800	mm
Side-opening sectional door or sectional horizontal sliding door	2350	mm
Up-and-over, canopy door	3500	mm
Height (approx.)		
Up-and-over-door	2600	mm
Sectional door	2350	mm
Side hinged door **	2800	mm
Side-opening sectional door or sectional horizontal sliding door	2300	mm
Up-and-over, canopy door	1900	mm
Operating time	15	%

* door conforming to EN 12604, EN 12605

** with standard side hinged door fittings prod. no. 1501.
If a higher door is required, rails of the respective length must be ordered or install rail extensions. Please contact your stockist for more information.

Technical data

		Unit
Rated voltage	230	V/AC
Rated frequency	50	Hz
Light	max. 32.5 V, max. 34 W, BA 15s alternatively 24 V, 21 W, BA 15s	
Operating temperature range	-20 - +50	°C
Protection class	IP 20	
Workplace-specific emission value	< 75 dBA - drive only	
Max. traction and pressure force:	550	N
Rated traction	165	N
Rated current consumption:	0,7	A
Rated power consumption:	140	W
Maximum speed:	160	mm/s
Power consumption, stand-by:	~ 7	W
Weight:	18,0	kg
Packaging drive (L x W x H):	1090 x 178 x 158	mm
Packaging rail 2600 (L x W x H):	1980 x 240 x 180	mm

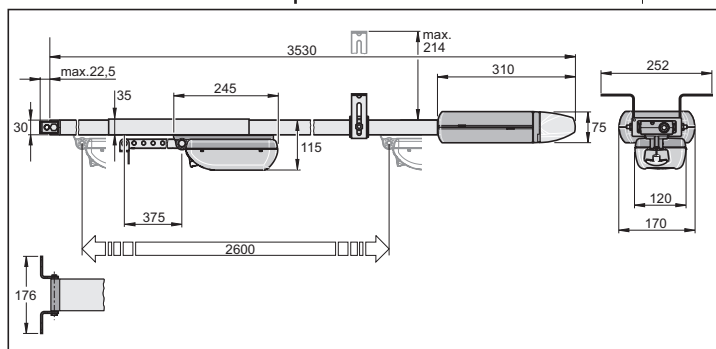

GB radio receiver

EU Conformity Declaration

Messrs

SOMMER Antriebs- und Funktechnik GmbH
Hans-Böckler-Straße 21-27
D-73230 Kirchheim/Teck

declares herewith that the product designated below complies with the relevant fundamental requirements as per Article 3 of the R&TTE Directive 1999/5/EG, insofar as the product is used correctly, and that the following standards apply:

Product: RF Remote Control for doors & gates

Type: RM01-868, RM02-868-2, RM02-868-2-TIGA
RM03-868-4, RM04-868-2, RM08-868-2
RM01-434, RM02-434-2, RM03-434-4, RM04-434-2
RX04-RM02-868-2, RX04-RM02-868-2-TT
RX04-RM02-434-2, RX04-RM02-434-2-TT

The relevant guidelines and standards are:

- ETSI EN 300220-2:2007-06
- ETSI EN 301489-1:2005-09
- DIN EN 60950-1:2006

Kirchheim/Teck, 21.06.2010

Werner Gollmer
Managing Director

Declaration of Installation

for the installation of an incomplete machine
in accordance with the Machinery Directive 2006/42/EC, appendix II, part 1 B

SOMMER Antriebs- und Funktechnik GmbH
Hans - Böckler - Straße 21 - 27
73230 Kirchheim unter Teck
Germany

hereby declares that the control unit

sprint evolution

as of the identification sprint evolution 01/10 complies with the Machinery Directive 2006/42/EC and is specified for installation in a door system.

- The following fundamental safety requirements in accordance with appendix I have been applied and observed:
 - General principles no. 1
 - 1.2 Safety and reliability of control units
 - Safety input I terminal 7 + 8: Cat 2 / PL C
 - Internal force limitation Cat 2 / PL C
 - Safety categories in accordance with EN 13849 - 1:2008
 - Compliant with the regulations of the EC Building Products Guideline 89/106/EC.
For the operating forces part, the respective initial testing has been carried out in consultation with recognized inspecting authorities. In doing so, the harmonized standards EN 13241-1, EN 12453 and EN 12445 have been applied. For the tested combinations, refer to the table "Reference list" on the Internet under www.sommer.eu.
 - Compliant with the Low Voltage Directive 2006/95/EC.
 - Compliant with the Directive on Electromagnetic Compatibility 2004/108/EC.
- The technical documentation was drawn up in accordance with appendix VII B.

The product may only be put into operation after it has been established that the door system complies with the regulations of the Machinery Directive.



Kirchheim, 12.08.2010

A handwritten signature in blue ink, appearing to read 'Jochen Lude', followed by a horizontal line.

Jochen Lude
Responsible for documents

General information

Scope of delivery

The scope of delivery may vary according to the type of drive supplied.

Package 1

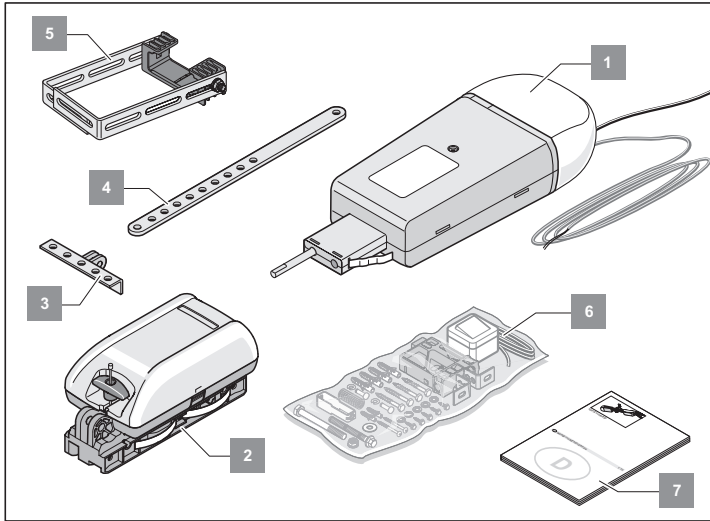

Package 2

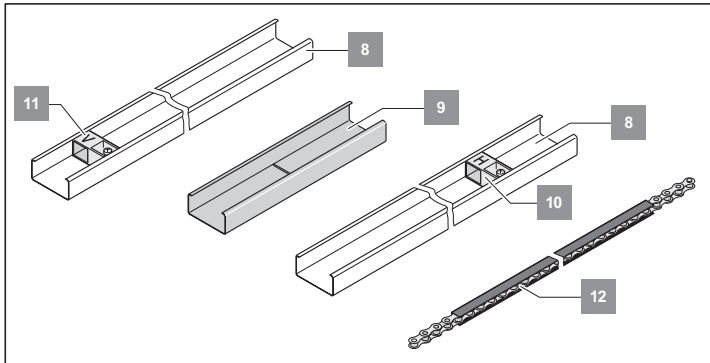

Item	Component	Quantity
1.	Control housing (push-button line, mains cable, illumination)	1
2.	Trolley	1
3.	Door fitting bracket	1
4.	Connecting arm	1
5.	Ceiling mount	1
6.	Assembly kit	1
7.	Installation and operating instructions	1
8.	C-rails (uncoated)	2
9.	Slide-on module (uncoated)	1
10.	Switch trigger "H"	1
11.	Switch trigger "V"	1
12.	Chain in chain case	1

Preparations for installation

Safety instructions

- The power cable supplied as standard may be neither shortened nor lengthened.
- The voltage of the power source must correspond to that indicated on the drive's rating plate.
- All devices requiring external connection must be equipped with safe contact separation as per IEC 364-4-41 to isolate them from the mains voltage supply.
- Live parts of the drive (voltage-carrying parts e.g. C-rails) may not be connected to earth or to the live parts or protective conductors of other circuits.
- IEC 364-4-41 must be observed when laying the external device conductors.



CAUTION! RISK TO LIFE AND LIMB!

Remove all ropes and loops that are required for the manual operation of the door.

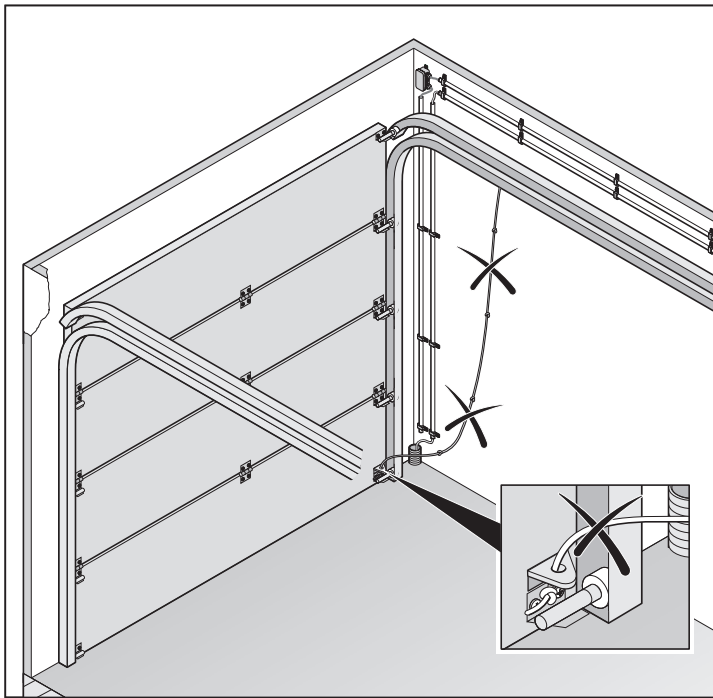

Tools required

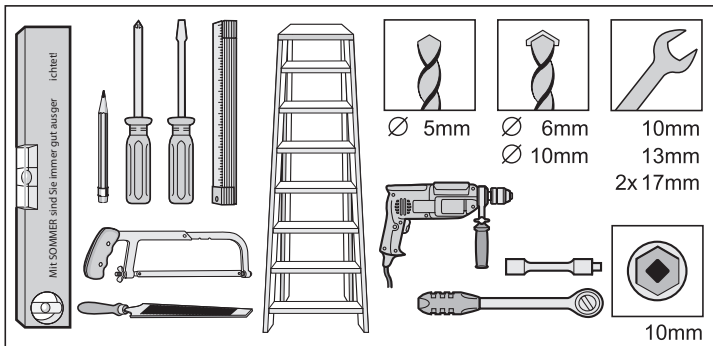

Personal protective equipment

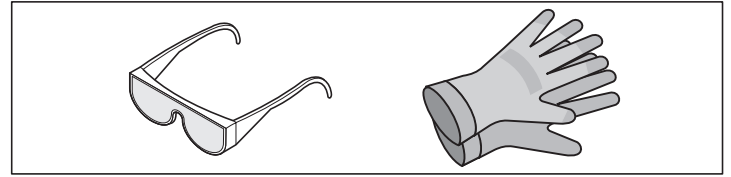

- Protective goggles (for drilling)
- Protective gloves (e.g. for handling cut perforated steel strips)

Installing a wicket door safety facility or release lock

- The door is fitted with a wicket door, but no wicket door safety facility
 - ⇒ Install a wicket door safety facility (see "Accessories" instructions).
- The door has no wicket door and the garage has no separate entrance
 - ⇒ Install a release lock or Bowden wire to facilitate release from the outside (see "Accessories" instructions).

Installation

Safety instructions

- Installation, connection and initial operation of the drive mechanism may only be carried out by qualified specialists.
- Do not operate the door when people, animals or objects are in its area of movement.
- Keep children, disabled persons and animals away from the door.
- Safety goggles should be worn when drilling the mounting holes.
- Cover the drive mechanism up when drilling to ensure it does not get soiled.

CAUTION
The walls and ceiling must be firm and stable. Only fit the drive mechanism to a correctly aligned door. A door that has not been aligned correctly can cause serious injuries.

- Doors must be stable because they are subjected to high traction and pressure forces. Light doors made of plastic or aluminium must be strengthened before installation if necessary. Ask your specialist retailer for advice.
- Remove door locking system or disable same.
- Only use approved fixing materials (e.g. screws, plugs). Ensure the fixing material is appropriate for the material the ceilings and walls are made of.
- Check that the door runs easily.
- The door must be balanced.

TEST:
Manually open the door half-way. It must stay still in this position. If the door moves downwards or upwards, mechanically readjust it. Ask your specialist retailer for advice.

Check the distance between the highest door position (THP, see fig. 11) and the ceiling. The distance between THP and the lower edge of the C-rail must be between minimum 5 mm and maximum 65 mm, whereby the push rod must be at an angle of max. 30° (see fig. 11)! If the clearance is less than is permissible, the drive mechanism must be moved back and an extended drive rail fitted. Ask your local stockist for advice.

Door types and special accessories*

* Accessories are not included in the delivery

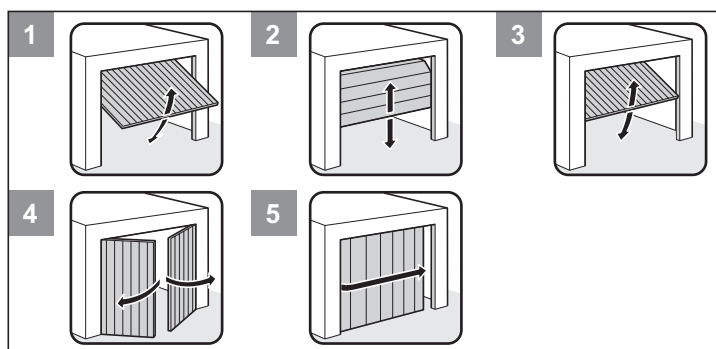

No.	Door type	Accessories
1	Up-and-over-door	No special accessories required
2	Sectional door with single runner rail	Sectional door fitting with boomerang*
2	Sectional door with double runner rail	Sectional door fitting without boomerang
2	Sectional overhead door	No special accessories required
3	Up-and-over, canopy door	Tilting arm **
4	Side hinged door	Side hinged door fittings *
5	Sectional horizontal sliding door, side-opening sectional door	Please consult specialist retailer

Installation tips

- Check that all the parts have been supplied before you start installation work in order to save time and unnecessary work if a part is missing.
- Installation work can be carried out quickly and reliably by two persons.
- It is important to note that the door does not bend as a result and jam in the guide rails.

CHECK:
Open and close the door several times by hand holding it at the point where you intend fitting the drive mechanism. If the door can be moved in this way without difficulty (in compliance with the above forces), then the drive mechanism can be fitted at this point.

Emergency release

If the garage has no separate entrance (e.g. wicket door), the user must be able to operate the emergency release mechanism from the outside. This is why the emergency release should be run to the outside where it can be activated via a Bowden wire or a release lock. The backjump (DIP switch 6 ON) must always be switched on in this case. See chapter "Functions and connections - backjump (DIP 6)"

Up-and-over-door

As the mechanical lock of a door with a drive mechanism has to be dismantled or deactivated, it is possible to open the door manually up to approx. 50 mm depending on the door construction. To counter this, spring latches can be fitted and these lock the door in addition to the drive. These spring latches are connected to the drive via a locking set in order to first unlock the spring latches before a drive opens the door when opening the door.

Side hinged door, sectional horizontal sliding door or side-opening sectional door

In the case of drives that push open a door of the above-mentioned type (see fig. below), the connections made in the direct socket unit must be swapped around as follows: See chapter "Functions and connections - direct socket unit (push-button 1)"

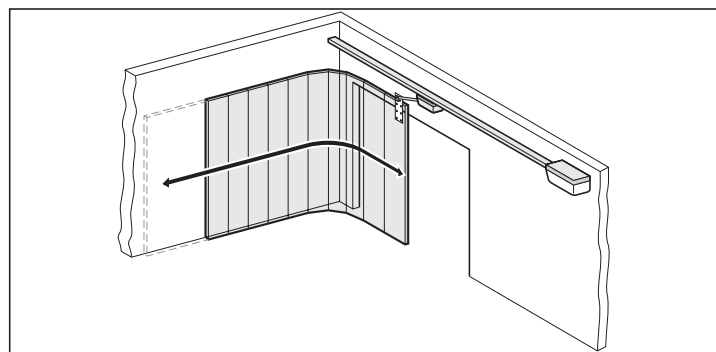

Other pulse generators include: hand-held transmitters, funkcodys, radio-operated interior switches and key-operated switches. In the case of the hand-held transmitters, funkcodys and radio-operated interior switches, no cable need be run to the drive. Contact your local dealer for advice.

Adjustment of the top roller in a sectional door

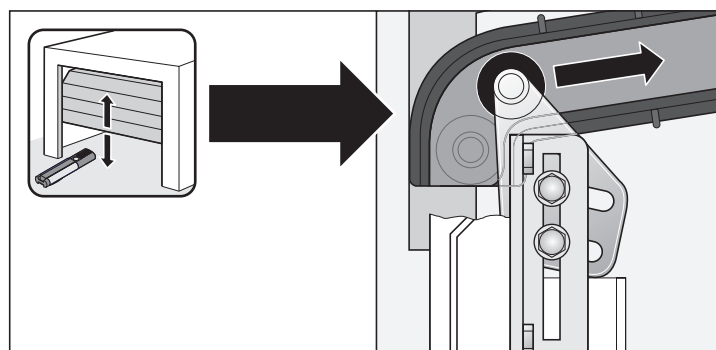

Installation

Pre-installation

Open both packages and check the scope of delivery.



PLEASE NOTE!

Dispose of packaging material according to the applicable statutory regulations.



CAUTION!

The plastic chain is not packaging - do not remove! Ensure the chain is always fully clipped in to the chain case and that all parts of the chain case are pushed together so that they are flush.

Remove both C-rails (8), slide-on module (9) and control housing (1) from the packaging (see chapter "General information - scope of delivery"), lay out in the garage (control housing (1) is inside the garage) and have tools to hand.



CAUTION!

Make sure all components are not placed directly on the hard base. Use cardboard, sheets or such to provide a soft base.

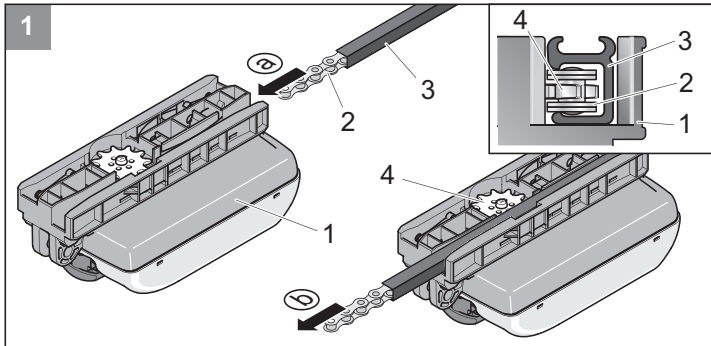

- Slide the chain (2) into the trolley (1) from behind. In doing so, ensure that the profiled side of the chain case (3) is facing upwards, so that the chain (2) runs correctly over the toothed wheel (4).

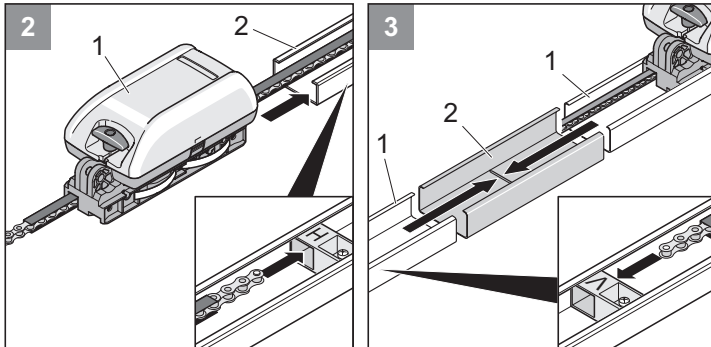

- Position the contact springs of the trolley. Push the trolley (1) with the chain in the rails (2) with the red switch trigger marked "H". The tip of the switch trigger must point towards the trolley (1). Push the chain through the opening in the red switch trigger "H".
- Slide the two rails (1) on the slide-on module (2) as far as they will go. You now have a single continuous rail. When pushing together the rails, ensure that the chain is caught by the red switch trigger "V". The tip of the switch trigger must point towards the trolley (1).

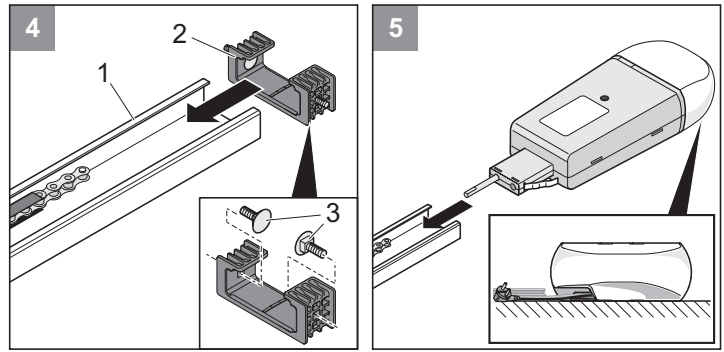

- Insert screws (3) into the ceiling bracket (2). Slide the ceiling bracket with inserted screws onto the rear end of the rail. The switch trigger "H" is located at the rear end of the rail.
- Slide the control housing onto the rear end of the rail as far as it will go, in doing so, positioning the contact springs of the trolley. Ensure that the chain fixing bolts of the control housing are on the same side as the chain case in the rail.



CAUTION !

The cable guide must be on the bottom of the control housing.

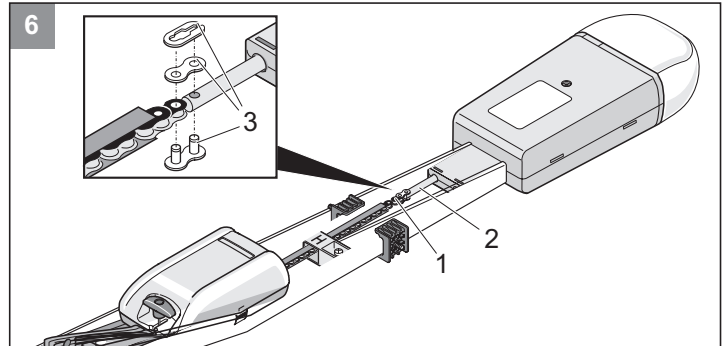

- Use the chain connecting link (3) to connect the chain (1) with the chain fixing bolts of the control housing (2).

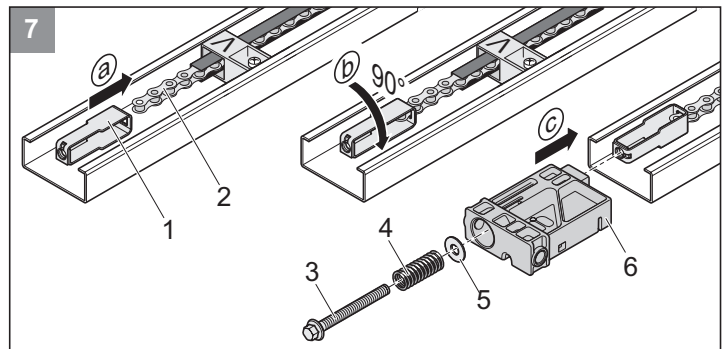

- Fit the tensioning element (1) into the chain (2)
 - Turn the tensioning element 90°.
 - Slide the plug-in unit (6) onto the rail and push the tensioning element through it. Position the washer (5) and spring (4) on the tensioning screw (3) and screw it into the tensioning element.

Installation

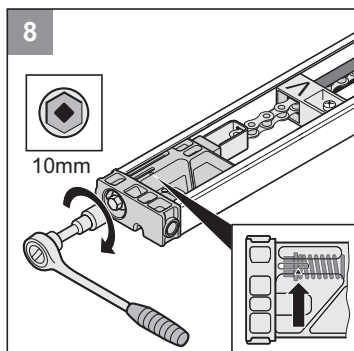

8 Tighten the chain as far as the mark (arrow).

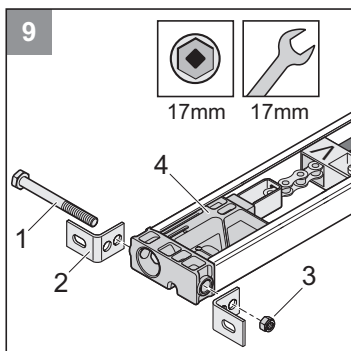

9 Use screw (1) and nut (3) to fix the two camber brackets (2) to the plug-in unit (4), but do not yet tighten fully.

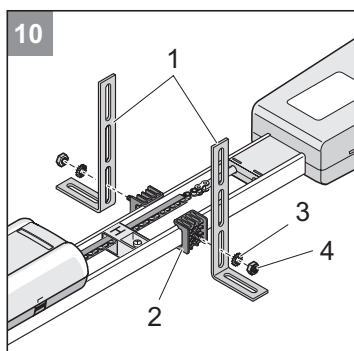

10 Use nut (4) and toothed lock washer (3) to fit the two steel brackets (1) to the ceiling bracket (2).

Installation



CAUTION!

Use a non-slip, stable stepladder!

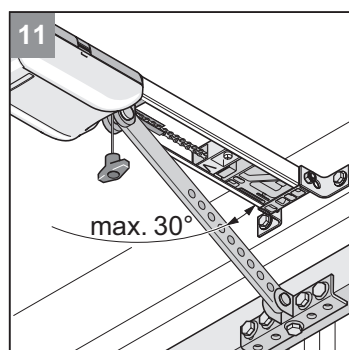
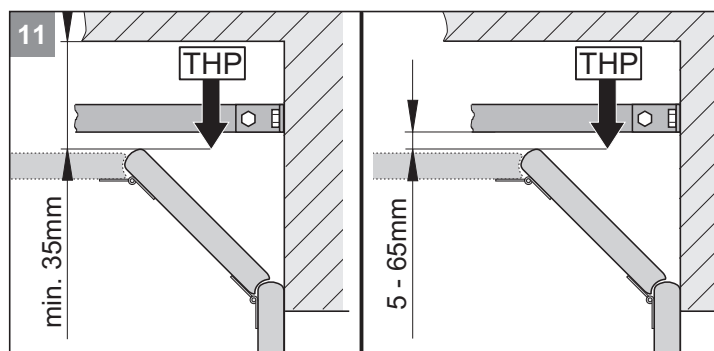
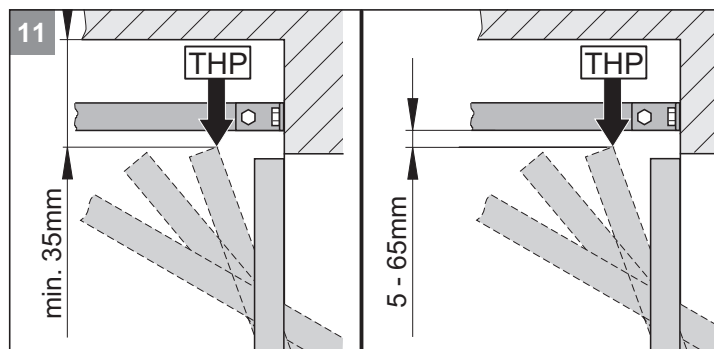

PLEASE NOTE

If the distance between the ceiling and the lower edge of the C-rail is greater than 245 mm, then extend the suspension bracket (with perforated steel strip).



PLEASE NOTE

Please note that this distance might be smaller, if the door handle is located at the centre of the door. Ensure that the door movement is not obstructed.

- 11** Determine the door's highest up-position (THP):
Open the door and measure the smallest clearance (min. 35 mm) between the top edge of the door and the ceiling. The distance between THP and the lower edge of the C-rail must be between minimum 5 mm and maximum 65 mm, whereby the push rod must be at an angle of max. 30°!

Installation

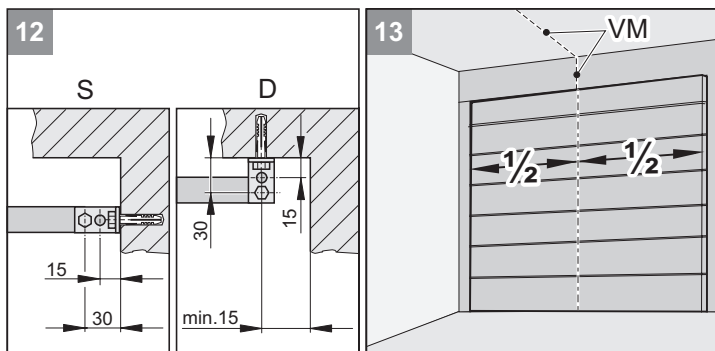

i PLEASE NOTE!
For installation on the ceiling (D), drill holes at distances of 15 mm, if possible. Smaller angle of inclination of the fixing brackets.

- 12** The drive mechanism can be mounted on lintel (S) or ceiling (D).
13 Measure front centre point (VM) of door and mark on door and on lintel or ceiling.

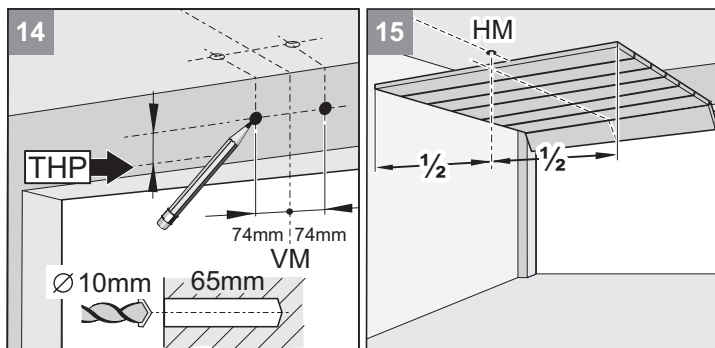

- 14** Make a mark 74 mm to right and left of centre of door (VM) at same height on lintel or ceiling (see fig. 12). Drill two holes (Ø 10 x 65 mm deep).
15 Open door. Transfer door centre mark (HM) on to the ceiling. Close door.

i PLEASE NOTE!
When safety goggles when drilling!
Check thickness of ceiling, particularly in the case of prefabricated garages!

- 15** Open door. Transfer door centre mark (HM) on to the ceiling. Close door.

i PLEASE NOTE!
Protect control housing (6) from damage!

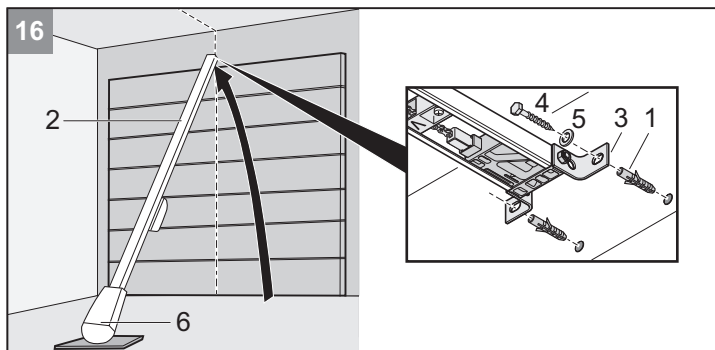

- 16** Insert plug (1). Lift up drive mechanism (2) at the front. Secure lintel fitting (3) at front with two screws (4) and plain washers (5).

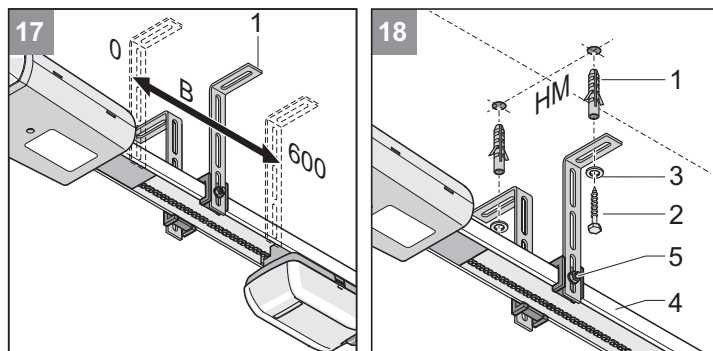

! CAUTION!
Always mount the drive in parallel to the runner rails of the door.

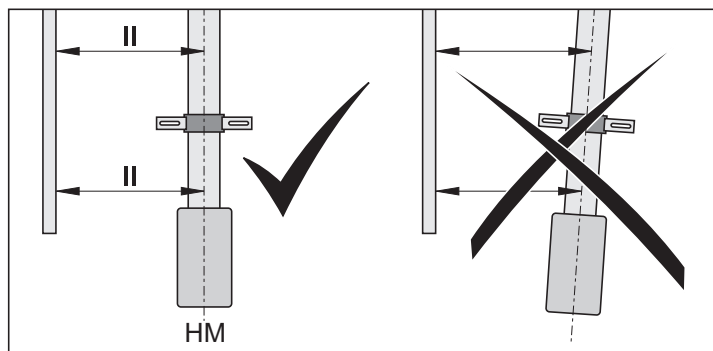

- 17** Lift up drive. Align ceiling bracket (1). It should be located within a range of B = 0 ... 600 mm.
18 Align drive mechanism horizontally to rear centre of door (HM). Mark position of holes. Drill two holes (Ø 10 x 65 mm deep).

i PLEASE NOTE!
Wear safety goggles when drilling! Check the thickness of the ceiling, especially in the case of prefabricated garages!

- 18** Insert plug (1). Fit two screws (2) with plain washers (3). Tighten screws (2). Align C-rail (4) at the correct height (use a spirit level if necessary). If necessary, move screws (5). Tighten screws (5).

Installation

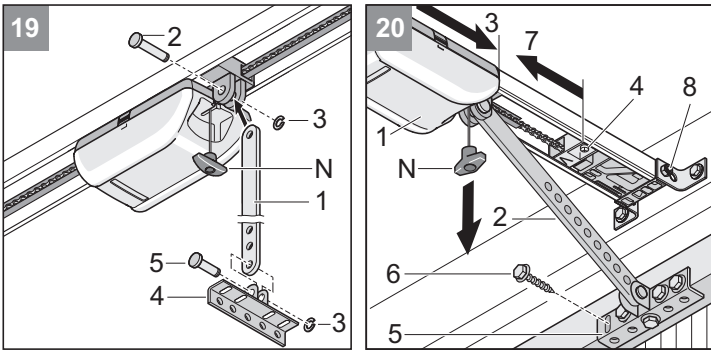

i PLEASE NOTE
Use screws that are appropriate to the door material.
Wear safety goggles when drilling!

- 19** Mount connecting arm (1):
Insert the long bolt (2) and slide on the securing clip (3).
Attach the door fitting bracket (4) to the connecting arm (1) using the short bolt (5) and slide on the securing clip (3).
- 20** Pull once on the emergency release wire (N). The trolley (1) is disengaged. Tighten screw (8) on the lintel fitting.
Push the trolley (1) with the connecting arm (2) as far forward as possible (3). If necessary, release the switch trigger (4).
Align the door fitting bracket (5) to the door centre mark (VM) and mark 5 drill holes. Drill 5 holes (Ø 5 mm).
- 20** Insert 5 hexagon-head screws (6) and tighten securely.
Release the switch trigger (4) and push right up to the trolley (7).
Tighten the switch trigger (4) screw securely.

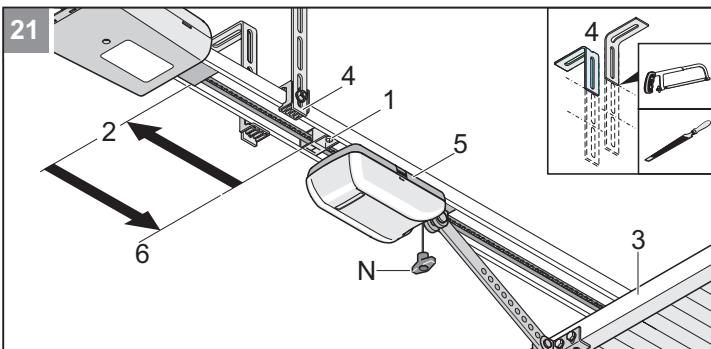

i PLEASE NOTE
Trim (e.g. saw off and debur) the projecting part of the ceiling bracket (4).

- 21** Release the rear switch trigger (1) and push all the way to the back until the stop (2). Open the door (3) manually.
Push the switch trigger (1) right up to the trolley (5). Securely tighten the screw on the switch trigger (1).

Fitting and connecting push-buttons

! **CAUTION!**
Position the push-button in such a way that the operator can see the door, while he/she is not inside the operating area of the door.

i PLEASE NOTE
Never run the push-button cable (length 7 m) along a power cable as this can cause the control unit to malfunction. The control unit is shipped with the push-button cable connected. Lay push-button cable and secure in position.

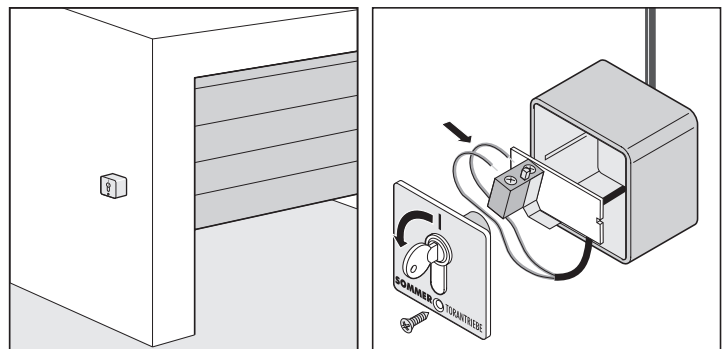
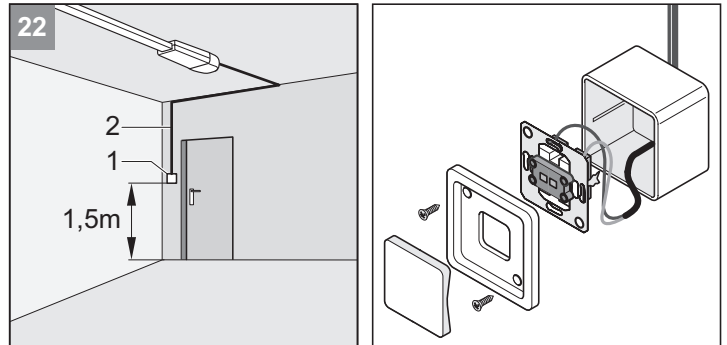

- 22** Install push-button (1) in an appropriate, easily accessible location inside the garage. Minimum height from floor: 1.6 m
Install the push-button cable (2) in the garage. Connect end of cable to the push-button (1).

Installing the socket outlet

! **CAUTION!**
Socket may only be installed by a qualified electrician. Protect socket with a fuse (16 A slow-blow type). Observe all applicable regulations (e.g. VDE, etc.)!

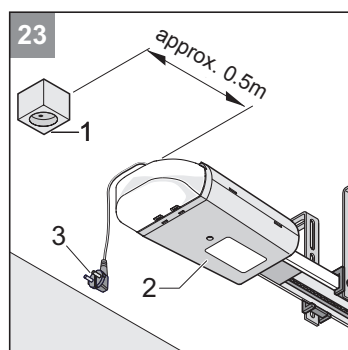

- 23** Install socket (1) on ceiling at a distance of approx. 0.5 metres to the control housing (2).
Install and connect the line from the power socket (1) to the power mains.

! **CAUTION!**
Do not plug the power supply (3) into the socket outlet yet!

Commissioning

Safety instructions



RISK OF INJURY!

The force setting is relevant to the system's safety and must therefore be carried out with due care and attention. An excessively high force setting can injure people and/or animals and damage property.
Select as low a force setting as possible to ensure that obstacles are identified in a fast, safe manner.



RISK OF SUDDEN CLOSING OR OPENING!

When the emergency release is actuated, the door might suddenly be opened or closed, due to a damaged spring or incorrect balance weight. This might damage or even destroy the drive unit.



PLEASE NOTE!

Once the drive has been installed, the person responsible for installation has to issue an EU Conformity Declaration for the door system in accordance with Machine Directive 98/37/EC as well as fitting the CE seal and the rating plate.
This also applies to doors installed for private purposes and in cases where the drive has been retrofitted to a manual door. These instructions as well as the drive's installation and operating instructions should be kept by the user for reference purposes.

Setting door OPEN + CLOSED end positions



PLEASE NOTE!

While adjusting the settings, open and close the gate manually. Do not operate it with the engaged drive system.

The distance over which the drive mechanism moves the door can be increased/reduced by using the switch trigger (V + H).

Check that the door opens and closes completely. If it does not, its travel or the end positions must be adjusted.

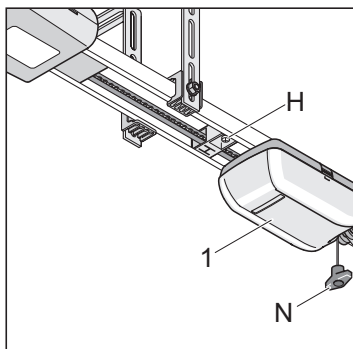
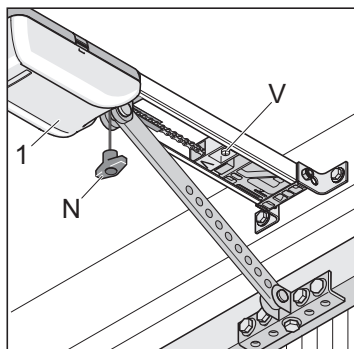

Door CLOSED end position

1. Release the trolley. Pull once on the emergency release wire (N). It must be possible to slide the trolley back and forth by hand.
2. Manually close the door.
3. Release the switch trigger (V) and slide it towards the trolley until it clicks.
⇒ The end switch switches on
4. Secure the switch trigger (V).

Door OPEN end position

1. Manually open the door.
2. Release the switch trigger (H) and slide it towards the trolley until it clicks.
⇒ The end switch switches on
3. Secure the switch trigger (H).
4. Manually close the door.

Lock the trolley (1) :

1. Pull once on the emergency release wire (N).
2. Move the trolley by hand slightly forwards until the
⇒ chain wheel engages with a loud clicking sound.

Teaching in drive

The control has an automatic force setting. Whenever the door "OPENS" or "CLOSES", the control unit automatically reads in the force required and memorises it when the end position is reached.



CAUTION!

Before connecting the power supply, ensure that the voltage of the power source corresponds to that indicated on the drive's rated plate.

1. Plug in the power supply.
⇒ Lamp (2) flashes

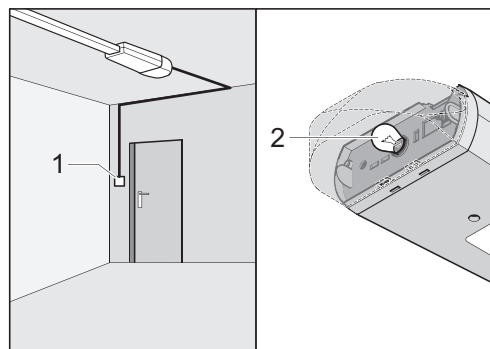

PLEASE NOTE

The first movement of the drive after the power is connected must be "door OPEN". If this is not the case, exchange the wires to terminals 3 + 4.

2. Press the push-button (1).
⇒ The door opens to end position "door OPEN".
3. Press the push-button (1).
⇒ The door closes until end position "door CLOSED".
4. Resetting the control unit. The control reset is carried out in accordance with the procedure for the given drive type: See chapter "Operation/handling - control reset".

Carry out the following procedure twice:

1. Press the push-button (1) once.
⇒ Door opens as far as the switch trigger (H, door OPEN)
⇒ Lamp (2) flashes
2. Press the push-button (1) once.
⇒ Door closes as far as the switch trigger (V, door CLOSED)
⇒ Lamp (2) flashes
3. When all force values are read and saved, the lamp (2) ceases flashing.
⇒ The drive has been "taught" successfully!

Checking the end positions door OPEN + CLOSED

The trolley of the drive system can be extended or shortened by means of the switch triggers.

Check that the door opens and closes completely. If it does not, readjust the trolley.

Commissioning

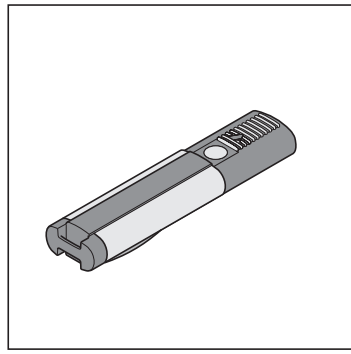
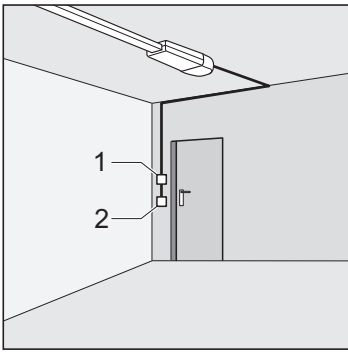

1. Actuate the control device (e.g.: push-button, hand-held transmitter, etc.) once.
⇒ The door opens to end position "door OPEN".
2. Check that the door has reached the desired end position.
⇒ Readjust the end positions if necessary. See chapter "Commissioning - setting door OPEN + CLOSED end positions".

Checking emergency release



PLEASE NOTE!

With sectional doors, or doors with ceiling guides, you have the option of activating the backjump with DIP switch 6 in order to offload the operator and door mechanisms. Easier operation of the emergency release.

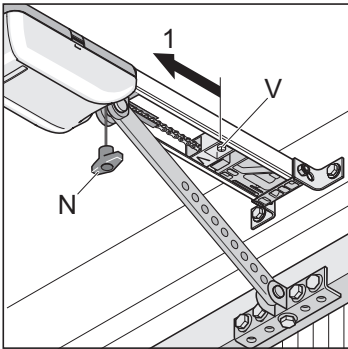

1. Close the door with the drive.
2. Pull the emergency release (N) once.
If the emergency release cannot be operated, loosen the end switch (V) and move it in direction (1).
3. Open the door with the drive and close it again. Test the emergency release.

Checking force setting

Whenever the door is opened or closed, the control unit compares the memorised force setting with the force actually needed and automatically adjusts the memorised setting accordingly when the given end position is reached.

Check: See chapter "Maintenance and care - regular checks".

Programming of hand-held transmitter



PLEASE NOTE!

Prior to the initial programming of the hand-held transmitters, clear the memory of the radio receiver.

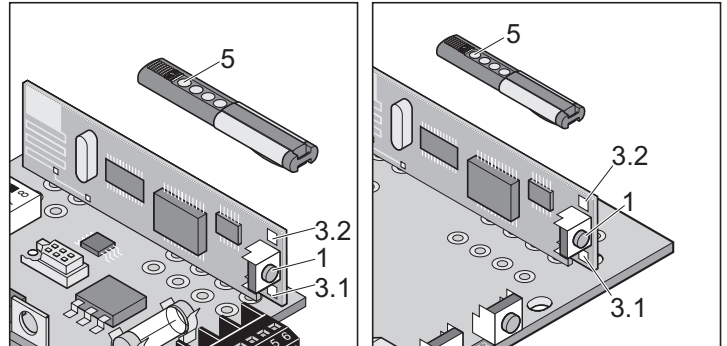

Clearing radio receiver memory

1. Press and hold the programming key (1).
⇒ After 5 seconds, the LED (3.1 or 3.2) flashes.
⇒ After another 10 seconds, the LED is constantly on (3.1 or 3.2).
⇒ After a total of 25 seconds, all LEDs are on (3.1 + 3.2).
2. Release the programming key (1). All channel data has been deleted.

Programming of hand-held transmitter

1. Press the programming key (1).
 - 1 x for channel 1, LED (3.1) is on
 - 2 x for channel 2, LED (3.2) is on
 ⇒ If no other code signal is transmitted within 10 seconds, the radio receiver switches to standard operation.
2. Press and hold desired hand-held transmitter key (5) until the LED (3.1 / 3.2) is off (depending on the selected channel).
⇒ The LED is off - the programming process is completed.
⇒ The hand-held transmitter has transmitted the radio codes to the radio receiver.
3. Continue with programming the other hand-held transmitters. To do this, repeat the above steps. The maximum number of memory blocks is 112 per radio receiver.

Aborting programming:

repeatedly press the programming key (1) until all LEDs are off.

Attaching instruction label

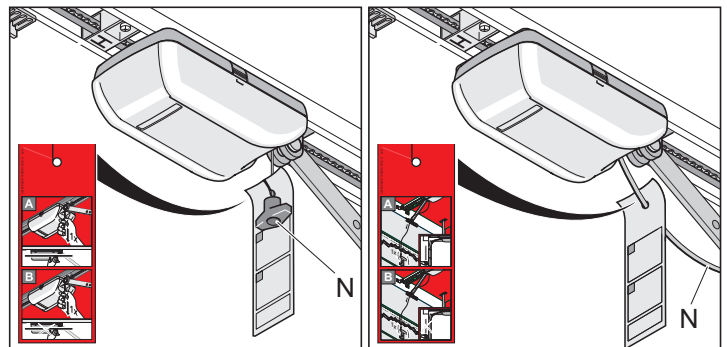

Attach the instruction label for the operation of the emergency release to the emergency release rope.

Commissioning

Attaching warning sign

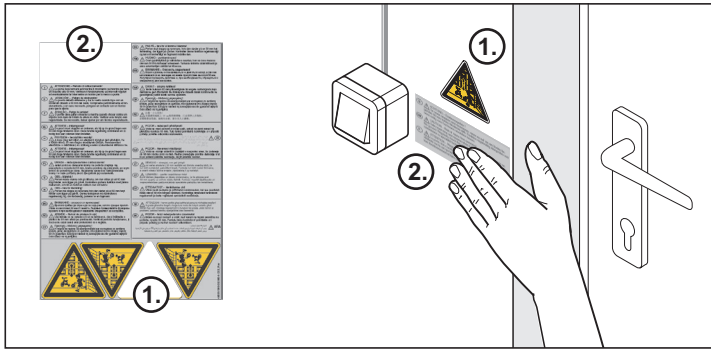

Attach the warning signs (text + triangle sign) at a position where they are clearly visible, e.g. beside the push-button (warning triangle) and on the door leaf (text + warning triangle).

Operation / handling

Safety instructions

- Keep children, disabled persons and animals away from the door.
- Keep your hands clear of any moving door or any moving parts.
- Only drive into and out of the garage when the door is fully opened.
- Risk of persons trapping or cutting themselves in/on the door system's moving parts or edges where it closes.

Opening door

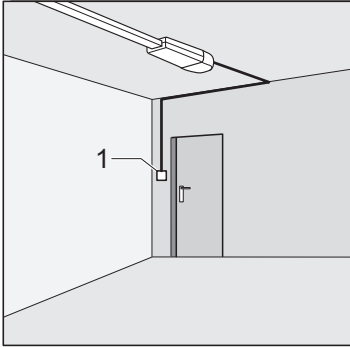

1. Press push-button (1) or hand-held transmitter key once to open the door.
2. With door "OPEN", press the push-button (1) again.
 - ⇒ The door stops moving (dependent on the DIP switch 7).
3. Press the push-button (1) again.
 - ⇒ The door closes (dependent on the DIP switch 7).

Closing door

1. Press push-button (1) or hand-held transmitter key once to close the door.
2. With door "CLOSE", press the switch (1) again.
 - ⇒ The door stops moving (dependent on the DIP switch 7).
3. Press the push-button (1) again.
 - ⇒ The door opens (dependent on the DIP switch 7).

Pulse sequence of door movement

Adjust the pulse sequence with DIP switch 7.

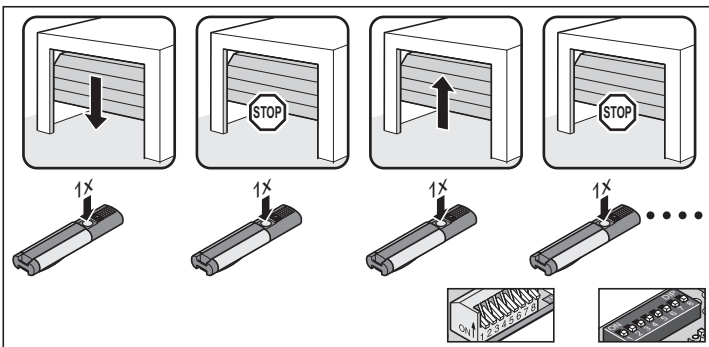

DIP 7 OFF, default settings for all drives (see illustration):

- open - stop - close - stop - open - ...

DIP 7 ON:

- Push-button 1: open - stop - close - stop - ...
- Push-button 2: close - stop - close - stop - ...

Emergency release



CAUTION!

The emergency release may only be used in the event of an emergency, (power failure, failure of drive, etc.) to open or close the door. Do not use it to open and close the door in other situations. This could damage the door or the drive mechanism.



RISK OF SUDDEN CLOSING OR OPENING!

When the emergency release is actuated, the door might suddenly be opened or closed, due to a damaged spring or incorrect balance weight. This might damage or even destroy the drive unit.



PLEASE NOTE

Engaging or disengaging the drive can occur in any door position.

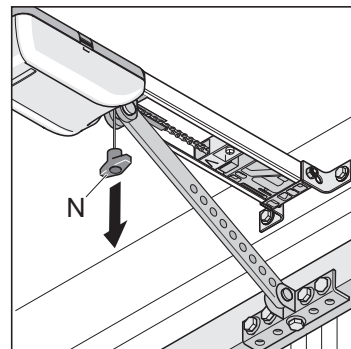

1. Pull once on the emergency release wire (N).
 - ⇒ the drive mechanism disengages and the door can be opened manually.
2. Pull once again on the emergency release wire (N).
 - ⇒ the drive mechanism locks and the door can only be moved with the drive.



PLEASE NOTE!

Door is fitted with a wicket door but no safety mechanism for the wicket door - retro-fit wicket-door safety mechanism (see 'Accessories' instructions).
 Door has no wicket door and garage no second entrance - install release lock or Bowden wire providing outside release access (see 'Accessories' instructions).

Control reset

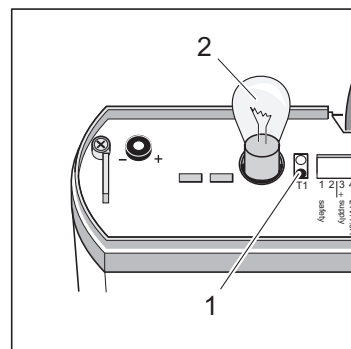

1. Press switch (1) until the light bulb (2) goes out.
 - ⇒ Light bulb (2) out - force setting deleted
2. Release the switch (1).
 - ⇒ Light bulb (2) flashes - control reset successful

Operation / handling

The light bulbs may differ depending on the DIP switch:

- DIP switch 4 ON, light bulb (2) is on after the control reset
- DIP switch 4 OFF, light bulb (2) flashes after the control reset.

i PLEASE NOTE!
After a control reset, the drive must be programmed again.

Interim stop

If an interim stop occurs due to the operation of a push-button or the hand-held transmitter, the drive unit stops immediately. The next command given sends the drive in the opposite direction. See 'Operation/handling - pulse sequence of door movement' section.

Safety stop 1 (force cut-off)

When the automatic force cut-off is activated, the drive stops or reverses. The next command given sends the drive in the opposite direction. See 'Operation/handling - pulse sequence of door movement' section.

- Safety stop when door closes - door reverses
- Safety stop when door opens - door stops

Safety stop 2 (safety input)

When the safety input is tripped (e.g. someone crosses light barrier), the drive stops, reverses or opens, depending on the given DIP switch setting:

See chapter "Functions and connections - obstacle recognition" for a description of the setting options and DIP switches.

Default settings DIP switch 1 and 3 OFF:

- safety input tripped when door closes: door reverses
- safety input tripped when door opens: no response (door opens)

Overload protection

If the drive mechanism is subjected to excessive strain when opening or closing the door, this is recognised by the control unit which then stops the drive mechanism. After approx. 20 seconds or a control reset, the control deactivates the overload protection.

The drive mechanism can now recommence normal operation.

Operation following a power failure

The force values remain saved even during a power failure. The first movement of the drive after the power is connected must be "door OPEN".

Radio remote control receiver

i HOMELINK COMPATIBLE!
If your vehicle is equipped with a Homelink system (version 7), you can reach our drive/radio receiver at 868.6 MHz. With holder Homelink systems, you must use a different frequency (40.685 or 434.42 MHz). For more information, please visit: "<http://www.eurohomelink.com>"

Safety instructions

- To ensure safe operation, local safety regulations relevant to the equipment concerned must be observed! Information regarding this can be obtained from electricity suppliers, the VDE and employers' liability insurance associations.
- The operator of this radio-controlled equipment is in no way protected from interference from other telecommunications systems and facilities (e.g. other radio-controlled equipment that is licensed to operate at the same frequency range).
- Try replacing the batteries should reception problems be encountered.

Description of display and push-buttons

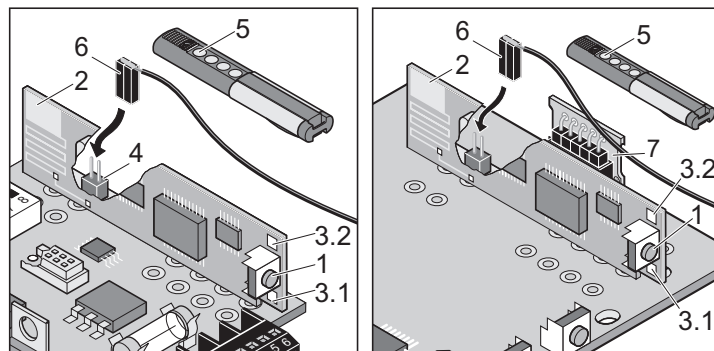

- | | |
|---|--|
| 1 | Setting button - puts the radio receiver in a given operating mode: <ul style="list-style-type: none">• self-learn• delete• normal |
| 2 | Internal aerial |
| 3 | LEDs - display which channel has been selected. <ul style="list-style-type: none">• 3.1 LED channel 1• 3.2 LED channel 2 |
| 4 | Connection for external aerial
If the radio range of the internal aerial is not sufficient, you have the option to connect an external aerial. |
| 5 | Hand-held transmitter key |
| 6 | External aerial |
| 7 | Storage module for radio codes (448) can be plugged in. |

Programming of hand-held transmitter

1. Press the programming key (1)
 - 1 x for channel 1, LED (3.1) is on
 - 2 x for channel 2, LED (3.2) is on⇒ If no other code signal is transmitted within 10 seconds, the radio receiver switches to standard operation.
2. Press and hold desired hand-held transmitter key (5) until the LED (3.1 / 3.2) is off (depending on the selected channel).
 - ⇒ The LED is off - the programming process is completed.
 - ⇒ The hand-held transmitter has transmitted the radio codes to the radio receiver.
3. Continue with programming the other hand-held transmitters. To do this, repeat the above steps. The maximum number of memory blocks is 112 per radio receiver.

Aborting programming:

repeatedly press the programming key (1) until all LEDs are off.

Deleting the hand-held transmitter key from the radio receiver

If a user of a multi-user garage facility moves house and wants to take his manual remote control with him, then all the codes of the given user's manual remote control have to be deleted from the radio receiver.

For security reasons, each key and each key combination of the hand-held transmitter should be deleted!

1. Press and hold the programming key (1) for 5 seconds.
 - ⇒ An LED flashes (doesn't matter which).
2. Release the programming key (1).
 - ⇒ Radio receiver is in delete mode.
3. Press a key on the hand-held transmitter, the code of which is required to be deleted.
 - ⇒ LED goes out. Deletion process complete.
4. Repeat procedure for all the keys and key combinations.

Deleting a channel from the radio receiver

1. Press and hold the programming key (1).
 - 1 x for channel 1, LED (3.1) is on
 - 2 x for channel 2, LED (3.2) is on⇒ After 5 seconds, the LED (3.1 or 3.2) flashes.
 - ⇒ After another 10 seconds, the LED is constantly on (3.1 or 3.2).
2. Release the programming key (1).
 - ⇒ Deletion process complete.

Clearing radio receiver memory

If a hand-held transmitter is lost, then for security reasons all channels on the receiver have to be deleted! After this has been done, all the hand-held transmitter controls must be re-set into the receiver.

1. Press and hold the programming key (1).
 - ⇒ After 5 seconds, the LED (3.1 or 3.2) flashes.
 - ⇒ After another 10 seconds, the LED is constantly on (3.1 or 3.2).
 - ⇒ After a total of 25 seconds, all LEDs are on (3.1 + 3.2).
2. Release the programming key (1). All channel data has been deleted.

Connecting an external aerial

An external aerial can be fitted if the possible range with the radio receiver's internal aerial is insufficient.

Connect the external aerial (6) to the terminal (4), see chapter "Operation/handling - description of display and push-buttons".

The aerial cable must not exert any mechanical load on the radio receiver. Fit strain relief.

What is push-button 2 used for?

Defined opening and closing (2-channel operation). This enables the door to be opened using one push-button, and closed using another.

Should this function be used, a 2nd push-button can be connected. For settings see chapter "Functions and connections - connecting push-button 2" as well as chapter "Functions and connections - defined opening and closing (DIP 7)" and "partial opening (DIP 8)"

Functions and connections

General information

- If the DIP switch is set to OFF; all auxiliary functions are switched off.
- Cable length max. 10 m with terminal: 9 + 10, 11 + 12
- Cable length max. 30 m with terminal: 5 + 6, 7 + 8

Obstacle recognition (DIP 1, 2 + 3)

Drive behaviour upon opening the door

If the door meets an obstacle (force cut-off) or if the safety input is interrupted (person triggering the light barrier), this is detected by the drive system, depending on the position of the DIP switch 1.

DIP switch 1

- OFF No response in the event of a safety input interruption. In the event of a force cut-off, the door is halted.
- ON Drive stops door

Drive behaviour upon closing the door

If the door meets an obstacle (force cut-off) or if the safety input is interrupted (person triggering the light barrier), this is detected by the drive system, depending on the position of the DIP switches 2 + 3.

DIP switch 2: Safety connection function

- OFF Opener contact for light barrier
- ON Push-button contact for push-button 2 (partial opening, defined opening and closing)

DIP switch 3: Behaviour of drive with door closing

- OFF Drive stops and opens the door a little, reversal
- ON Drive stops and opens the door completely

Connecting light barrier

- Permissible cable cross-section: max. 0.75 mm².

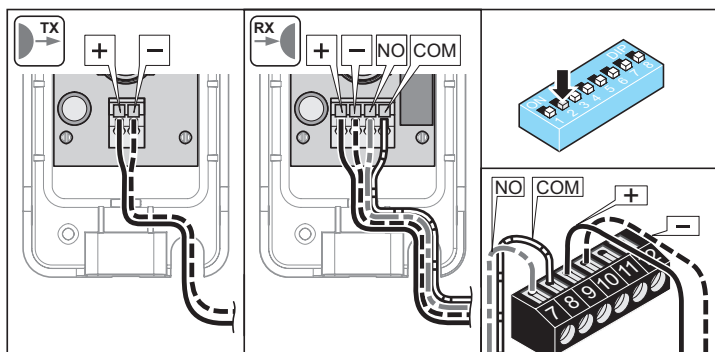

- Terminal 7 + 8 Safety connection, only if DIP switch 2 OFF
- Terminal 9 + 10 controlled DC 24 V, max. 0.1 A
 - Terminal 9: DC 24 V
 - Terminal 10: Earth

Settings: See chapter "Functions and connections - obstacle recognition (DIP 1, 2 + 3)".

Connecting push-button 2 (DIP 2)

- Permissible cable cross-section: max. 0.75 mm².



CAUTION

Use the contact only for potential-free normally closed contacts. External voltage may damage or even destroy the control unit.

Connect push-button 2 if the functions described below are required:

- defined opening and closing
- partial opening



CAUTION!

When using push-button 2 there is no further safety connection available.

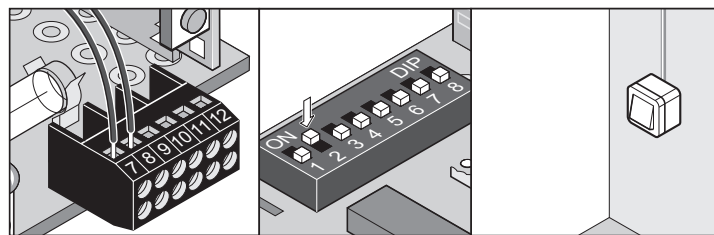

Terminal 7 + 8 Connection for push-button 2, only if DIP switch 2 ON

Connecting warning lamp (DIP 4)

- Permissible cable cross-section: max. 0.75 mm².

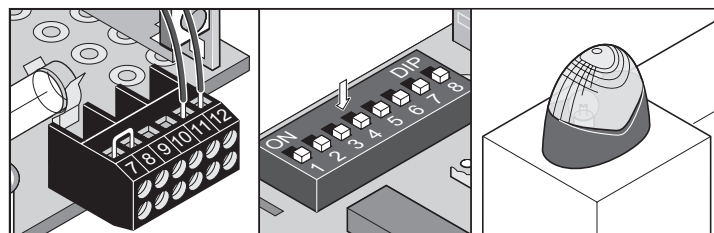

Terminal 11 + 12 uncontrolled DC 24 V (max. 34 Volt), max 1 A

DIP switch 4

- OFF connected warning lamp flashes (control unit generates flashing)
- ON door status indicator
 - is lit when door is not closed
 - is out when door is closed

Functions and connections

Direct socket unit (push-button 1)

i PLEASE NOTE
Swap connections (terminal 3 + 4) around if drive is to be used with a side hinged door.

➤ Permissible cable cross-section: max. 1.5 mm².

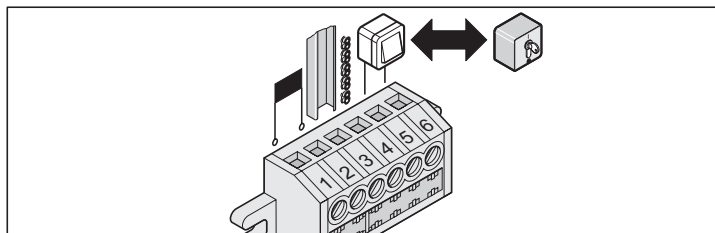

Terminal 1 + 2	Transformer
Terminal 3	C-rail
Terminal 4	Chain
Terminal 5 + 6	Push-button contact (push-button 1)

! CAUTION
Use the contact (terminal 5 + 6) only for potential-free normally closed contacts. External voltage may damage or even destroy the control unit.

Early warning time (DIP 5)

The warning lamp starts to flash after push-button is pressed or the hand-held transmitter is operated, before the drive starts. If the push-button is pressed again or the hand-held transmitter operated during the 3 seconds, the early warning period is ended prematurely.

The early warning time functions in conjunction with both internal lighting and with a connected warning lamp.

DIP switch 5

OFF	deactivated
ON	activated, internal lighting and warning lamp with flash for 3 seconds

Backjump (DIP 6)

i PLEASE NOTE!
With sectional doors, or doors with ceiling guides, you have the option of enabling the backjump with DIP switch 6 in order to offload the operator and door mechanisms. Easier operation of the emergency release.

This feature serves the purpose of supporting door and drive mechanism. The drive mechanism moves briefly back in a door OPEN direction once it has reached the door CLOSED end position.

DIP switch 6

OFF	deactivated
ON	activated

Defined opening and closing (DIP 7)

i PLEASE NOTE!
With this function, push-button 1 / radio channel 1 only opens the door and push-button 2 / radio channel 2 closes the door.

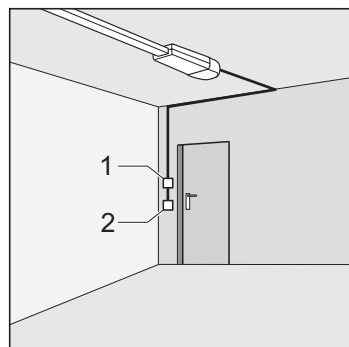

Push-button 1 / radio channel 1 open and push-button 2 / radio channel 2 close the door. This function can also be used with just 2 push-buttons or with just a hand-held transmitter.

Requirement:

- DIP switch 8 OFF
- 2 push-buttons connected (DIP switch 2 ON) or 2 hand-held transmitter buttons programmed.

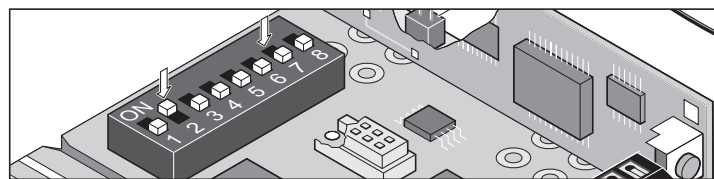

DIP switch 7

OFF	deactivated
ON	activated

Partial opening (DIP 8)

This function opens the door partially, depending on the given setting.

Ideas for use: garage ventilation, opening of side-opening door for personal access, to name but a few. Partial opening can also occur using just two push-buttons or just the manual remote control.

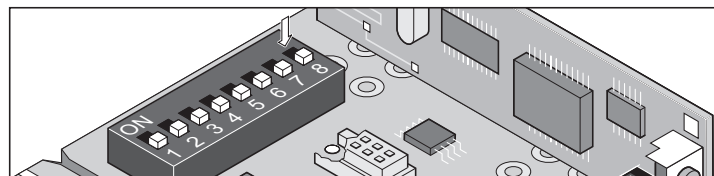

DIP switch 8

OFF	deactivated
ON	activated, DIP switch 7 not functioning

Partial opening with 2 push-buttons

Fit additional push-button and connect as push-button 2 to terminals 1 + 2.

- **Push-button 1** always opens door fully. If the door has been partially opened by pressing push-button 2, it can be fully opened by pressing push-button 1.
- **Push-button 2** only carries out partial opening when the door is closed. Should the door have been fully opened using push-button 1 or partially opened with push-button 2, it can be closed by again pressing push-button 2.

Functions and connections

Procedure:

1. Closing door.
2. DIP switch 8 ON: activates partial opening.
⇒ Always leave DIP switch 8 in ON position; the OFF position automatically deletes the partial opening function that has been set.
3. Press push-button 2 (opens door from CLOSED end position).
⇒ door opens until such time as push-button 2 is pressed again or OPEN end position has been reached.
4. Press push-button 2 when the desired position has been reached.
5. Close door by pressing push-button 2.



Partial opening has been memorised and door is opened to set position by pressing push-button 2. Set DIP switch 8 to OFF position to delete partial opening setting.

Partial opening via hand-held transmitter (2-channel operation)

Teaching in 2 hand-held transmitters. E.g. push-button 1 on to radio channel 1 and push-button 2 on to channel 2

- Radio channel 1 always has the same function as push-button 1
- Radio channel 2 always has the same function as push-button 2

Connecting an external aerial

Supplied vacant as standard

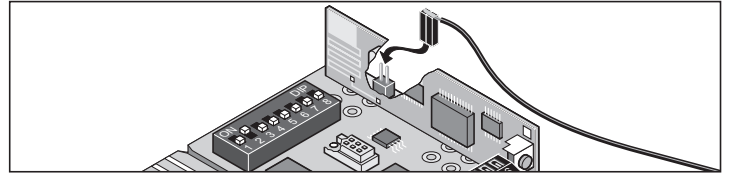

TorMinal interface

See TorMinal operating instructions

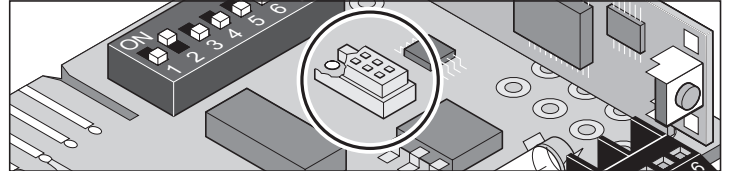

Trolley board

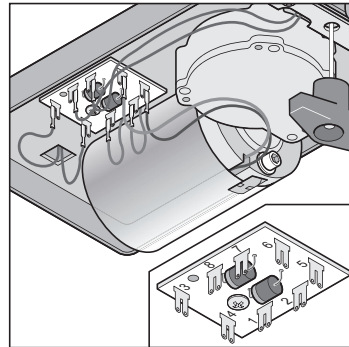

Terminal	1	Power supply to chain
Terminal	2	Power supply to rail
Terminal	3 + 4	End switch Door OPEN
Terminal	5	Motor cable
Terminal	6	Motor cable
Terminal	7 + 8	End switch Door CLOSED

Maintenance and care

Important information



DANGER!

Never use a hose or a high-pressure cleaner to spray down the drive or the control housing.

- Always disconnect the drive mechanism from the power supply before carrying out any work.
- Never use lyes or acids for cleaning purposes.
- Wipe drive clean with a dry cloth as required.
- Keep your hands clear of any moving door or any moving parts.
- Risk of persons trapping or cutting themselves in/on the door system's moving parts or edges where it closes.
- All fixing screws on the drive should be properly checked and tightened if necessary.
- Check the door at least annually, in accordance with the manufacturer's instructions.

Cleaning chain and drive unit rail

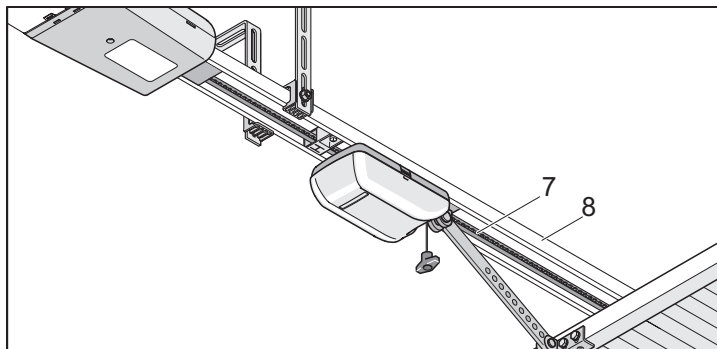

1. The chain (7) or the drive rail (8) is dirty - clean it with a cloth.
2. If required, lubricate the chain (7) and the drive rail (8) with conductive oil. Do not use grease!



PLEASE NOTE!

Recommended oil types: Ballistol, WD40 contact spray

Changing bulbs

1. Disconnect plug from the socket.

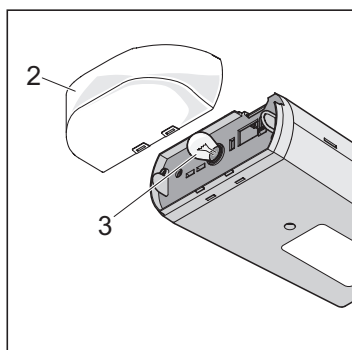

2. Remove light diffuser (2).
3. Turn bulb (3) anticlockwise and remove.
4. Fit new bulb (32.5 Volt, 34 Watt, BA 15s or 24 Volt, 21 Watt, BA 15s) and turn clockwise until it locks into position.

Changing fuses (connecting warning lamp)

1. Disconnect plug from the socket.

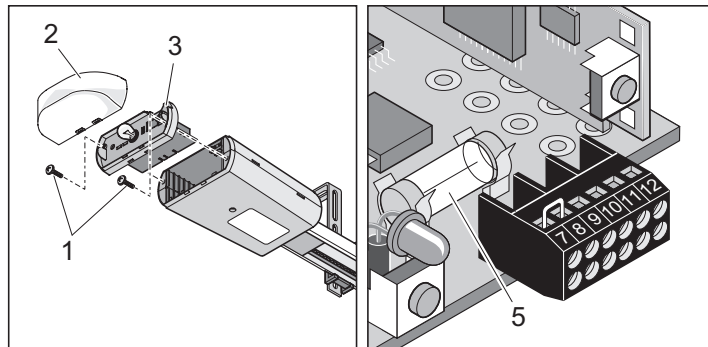

2. Remove light diffuser (2).
3. Remove screws (1).
4. Pull out the control (3).
5. Replace defective fuse, all fuses are 1 A fast acting. Fuse (5) for connecting warning lamp, terminal 11 + 12

Maintenance and care

Regular checks

Check safety devices regularly, every year at the very least, to ensure they function correctly. Refer to EN 12453:2000.

Safety devices that are sensitive to pressure (e.g. safety switch unit) should be checked every four weeks to ensure they function correctly, see EN 60335-2-95:11-2005.

Check	Behaviour	yes/no	Possible cause	Remedial action
Force cut-off Use 50 mm object to stop door wing from closing.	Drive reverses when contact with object is made	yes	<ul style="list-style-type: none"> Automatic cut-off of supply is working as it should 	<ul style="list-style-type: none"> Leave all settings as they are.
		no	<ul style="list-style-type: none"> Door incorrectly adjusted 	<ul style="list-style-type: none"> Have door correctly adjusted by a person qualified to do so!
Emergency release Adopt procedure described in chapter "Operation/handling - emergency release".	Emergency release can be activated easily (pull 1x, operator is unlocked)	yes	<ul style="list-style-type: none"> Everything in order! 	
		no	<ul style="list-style-type: none"> Drive stops door. Door and drive components are strained. Emergency release is defective. Door jam 	<ul style="list-style-type: none"> Adjust door CLOSED end switch or activate backjump (DIP switch 6 ON). Repair emergency release Check door. Refer to maintenance instructions for the door.
Safety switch unit, if provided Open/close door whilst, at same time, operating safety switch unit	Door behaves in accordance with setting of DIP switch 1,2 or 3.	yes	<ul style="list-style-type: none"> Everything in order ! 	
		no	<ul style="list-style-type: none"> Broken cable, loose terminal DIP switch maladjusted Switch unit defective 	<ul style="list-style-type: none"> Check wiring, tighten terminal connection. Correctly adjust DIP switch Take door drive mechanism out of operation and ensure it cannot restart by accident. Contact after-sales service!
Light barrier, if provided Open/close door whilst, at same time, interrupting the light barrier.	Door behaves in accordance with setting of DIP switch 1,2 or 3.	yes	<ul style="list-style-type: none"> Everything in order! 	
		no	<ul style="list-style-type: none"> Broken cable, loose terminal DIP switch maladjusted Light barrier soiled Light barrier maladjusted (bent bracket) Light barrier defective 	<ul style="list-style-type: none"> Check wiring, tighten terminal connection. Correctly adjust DIP switch Clean light barrier Correctly adjust light barrier Take door drive mechanism out of operation and ensure it cannot restart by accident. Contact after-sales service!

Disassembly



IMPORTANT!

Observe safety instructions!

The sequence of operations is identical to that described in the Section entitled "Installation" but in reverse order. The setting procedures described are not applicable.

Disposal

Observe appropriate local regulations!

Warranty and after-sales service

The warranty granted complies with statutory requirements. Contact your local stockist for any warranty claims.

Warranty entitlements only apply to the country in which the given drive was purchased.

Batteries, fuses and bulbs are not covered by the warranty.

If you require after-sales service, spare parts or accessories, please contact your specialist retailer.

We have made every effort to ensure that these instructions are as clear and concise as possible. However, if you have any queries or wish to comment on this document, please contact us with your suggestions:

Fax.: 0049 / 7021 / 8001-403

email: doku@sommer.eu

Troubleshooting

Further troubleshooting tips



HOMELINK COMPATIBLE!

If your vehicle is equipped with a Homelink system (version 7), you can reach our drive/radio receiver at 868.6 MHz. With holder Homelink systems, you must use a different frequency (40.685 or 434.42 MHz). For more details, visit www.eurohomelink.com or contact your local stockist.



IMPORTANT!

Many problems can be solved by a control reset (deletion of force values) and subsequent reprogramming of the operator!

Should you be unable to find and eliminate the fault with the help of this table, then take the following steps:

- Perform a control reset (delete force setting) on the control.
- Disconnect any accessories that may have been connected (e.g. light barrier).
- Set all DIP switches to default settings.
- If settings have been changed using the TorMinal, carry out a control unit reset using the TorMinal.
- Check all connections at the direct plug-type adapters and the terminal bar, and retighten them, if necessary.

To eliminate drive faults, follow the instructions in the table below. If you are encountering any difficulties, contact your stockist or visit the "http://www.sommer.eu" for support.

Fault	Possible cause	Remedial action
Lamp flashes	Drive is not programmed, no force values saved.	Teaching the drive. See chapter "Commissioning - teaching the drive".
Drive mechanism inoperative, lamp not lit	No mains power	Connect mains supply plug.
	No control unit installed	Install control unit.
	Fuse in garage circuit has blown	Replace the fuse. Use a different appliance, e.g. electric drill, to check the supply.
Lamp is not lit when door closes and opens	Bulb defective	Replace bulb. See chapter "Maintenance and care - changing bulbs".
Drive does not function	Control unit installed incorrectly	Slot control unit correctly into socket unit.
	Light barrier interrupted	Eliminate interruption.
	Safety switch unit (8.2 kOhm) defective or DIP switch 2 ON	Replace safety switch unit; set DIP switch 2 to OFF.
	Fraba system activated but light barrier or safety switch unit (8.2 kOhm) connected	Deactivate Fraba system, DIP switch 2 OFF.
Drive does not function when operated using hand-held transmitter	Battery in hand-held transmitter is flat	Change battery.
	Hand-held transmitter has not been taught in to radio receiver.	Programming of hand-held transmitter.
	Wrong radio frequency	Check frequency (868/434 MHz without external aerial).
	Command is permanently present as push-button is jammed.	Release push-button or replace hand-held transmitter.
Drive does not function when operated using push-button	Push-button not connected or defective	Connect push-button or replace.
Door stops when closing, moves approx. 10 cm in reverse direction then stops	Obstacle has tripped automatic force switch-off	Remove obstacle; open door completely.
	Incorrect force values "taught" or force tolerance is too low	Delete force values and repeat teach-in procedure.
	Switch-trigger set incorrectly	Reset switch-trigger; see chapter "Commissioning - setting door OPEN + CLOSED end positions".
	Door defective or door settings incorrect (e.g. spring shaft)	Have door adjusted correctly or repaired by a person qualified to do so.
Door stops when opening, moves approx. 10 cm in reverse direction then stops	Obstacle has tripped automatic force switch-off	Remove obstacle. Use push-button to close the door completely.
	Incorrect force values "taught" or force tolerance is too low	Delete force values and repeat teach-in procedure.
	Switch-trigger set incorrectly	Reset switch-trigger; see chapter "Commissioning - setting door OPEN + CLOSED end positions".

Troubleshooting

Fault	Possible cause	Remedial action
Door stops when opening	Connected light barrier interrupted and DIP switch 1 on ON	Eliminate interruption or set DIP switch 2 to OFF.
Drive does not close door	Power supply to light barrier interrupted.	<ul style="list-style-type: none"> • Check connection • Replace fuse
	Power supply to drive interrupted	The first command issued after restoration of the mains supply results in the drive opening the gate fully.
Drive opens door but then no further reaction to a command given via push-button or hand-held transmitter	Safety input tripped (e.g. light barrier defective)	<ul style="list-style-type: none"> • Remove obstacle from light barrier • Repair light barrier • Direct socket unit not plugged in correctly
	End switch "Door CLOSED" in the trolley defective	Replace end switch.
The drive closes the door; subsequently no response to pressing of button or hand-held transmitter	End switch "Door OPEN" in the trolley defective	Replace end switch.
Connected warning lamp does not light up	Fuse defective	Replace fuse, see chapter "Maintenance and care - changing fuses (connecting warning lamp)".
	Bulb defective	Replace bulb, see chapter "Maintenance and care - changing bulbs".
Opening or closing speed varies	Drive starts slowly and then picks up speed	'Soft run' mode - completely normal.
	Chain rail dirty	Clean rail and re-lubricate, see chapter "Maintenance and care - cleaning chain and drive unit rail"
	Chain rail lubricated with unsuitable oil	Clean rail and re-lubricate, see chapter "Maintenance and care - cleaning chain and drive unit rail".
	Incorrect chain tension	Tighten chain; see chapter "Installation - pre-installation".
Drive does not terminate 'Learn' sequence	End positions set incorrectly	Adjust end positions, see chapter "Commissioning - setting door OPEN + CLOSED end positions".
Only radio receiver! All LEDs flashing	All memory positions are occupied (max. 112)	<ul style="list-style-type: none"> • Delete all hand-held transmitters no longer in use • Install additional radio receiver.
LED 3.1 or 3.2 is continuously on	Radio signal is being received; hand-held transmitter button might be defective.	<ul style="list-style-type: none"> • Remove battery from the hand-held transmitter • Wait until the external signal decays.
LED 3.1 or 3.2 is on	Radio receiver is in 'teaching' mode and expects a code signal from a hand-held transmitter.	Press desired button on hand-held transmitter.